

HONDA
The Power of Dreams



32K0AC01
00X32-K0A-C010

XXX.XXXX.XX.K
PRINTED IN XXXXX

EN

CBF250NA/300NA / CB250R/300R

OWNER'S MANUAL

HONDA

CBF250NA/300NA / CB250R/300R



This manual should be considered a permanent part of the motorcycle and should remain with the motorcycle when it is resold.

This publication includes the latest production information available before printing. Honda Motor Co., Ltd. reserves the right to make changes at any time without notice and without incurring any obligation.

No part of this publication may be reproduced without written permission.

The vehicle pictured in this owner's manual may not match your actual vehicle.

Welcome

Congratulations on your purchase of a new Honda motorcycle. Your selection of a Honda makes you part of a worldwide family of satisfied customers who appreciate Honda's reputation for building quality into every product.

To ensure your safety and riding pleasure:

- Read this owner's manual carefully.
- Follow all recommendations and procedures contained in this manual.
- Pay close attention to safety messages contained in this manual and on the motorcycle.

- The following codes in this manual indicate each country.
- The illustrations here in are based on the CBF300NA ED type.

Country Codes

Code	Country
------	---------

CBF300NA

ED	European direct sales
----	-----------------------

CBF250NA

TU	Turkey
----	--------

*The specifications may vary with each locale.

A Few Words About Safety

Your safety, and the safety of others, is very important. Operating this motorcycle safely is an important responsibility.

To help you make informed decisions about safety, we have provided operating procedures and other information on safety labels and in this manual. This information alerts you to potential hazards that could hurt you or others.

Of course, it is not practical or possible to warn you about all hazards associated with operating or maintaining a motorcycle. You must use your own good judgement.

You will find important safety information in a variety of forms, including:

- Safety labels on the motorcycle
- Safety Messages preceded by a safety alert symbol  and one of three signal words: DANGER, WARNING, or CAUTION.

These signal words mean:

DANGER

You **WILL** be **KILLED** or **SERIOUSLY HURT** if you don't follow instructions.

WARNING

You **CAN** be **KILLED** or **SERIOUSLY HURT** if you don't follow instructions.

CAUTION

You **CAN** be **HURT** if you don't follow instructions.

Other important information is provided under the following titles:

NOTICE Information to help you avoid damage to your motorcycle, other property, or the environment.

Contents

Motorcycle Safety P. 2

Operation Guide P. 16

Maintenance P. 49

Troubleshooting P. 99

Information P. 117

Specifications P. 129

Index P. 132

Motorcycle Safety

This section contains important information for safe riding of your motorcycle.
Please read this section carefully.

Safety Guidelines	P. 3
Image Labels	P. 6
Safety Precautions	P. 10
Riding Precautions	P. 11
Accessories & Modifications	P. 14
Loading	P. 15

Safety Guidelines

Safety Guidelines

Follow these guidelines to enhance your safety:

- Perform all routine and regular inspections specified in this manual.
- Stop the engine and keep sparks and flame away before filling the fuel tank.
- Do not run the engine in enclosed or partly enclosed areas. Carbon monoxide in exhaust gases is toxic and can kill you.

Always Wear a Helmet

It's a proven fact: helmets and protective apparel significantly reduce the number and severity of head and other injuries. So always wear an approved motorcycle helmet and protective apparel. ➤ P. 10

Before Riding

Make sure that you are physically fit, mentally focused and free of alcohol and drugs. Check that you and your passenger are both wearing an approved motorcycle helmet and protective apparel. Instruct your passenger on holding onto the seat strap or your waist, leaning with you in turns, and keeping their feet on the footpegs, even when the motorcycle is stopped.

Take Time to Learn & Practice

Even if you have ridden other motorcycles, practice riding in a safe area to become familiar with how this motorcycle works and handles, and to become accustomed to the motorcycle's size and weight.

Safety Guidelines

Ride Defensively

Always pay attention to other vehicles around you, and do not assume that other drivers see you. Be prepared to stop quickly or perform an evasive maneuver.

Make Yourself Easy to See

Make yourself more visible, especially at night, by wearing bright reflective clothing, positioning yourself so other drivers can see you, signaling before turning or changing lanes, and using your horn when necessary.

Ride within Your Limits

Never ride beyond your personal abilities or faster than conditions warrant. Fatigue and inattention can impair your ability to use good judgement and ride safely.

Don't Drink and Ride

Alcohol and riding don't mix. Even one alcoholic drink can reduce your ability to respond to changing conditions, and your reaction time gets worse with every additional drink. Don't drink and ride, and don't let your friends drink and ride either.

Keep Your Honda in Safe Condition

It's important to keep your motorcycle properly maintained and in safe riding condition. Inspect your motorcycle before every ride and perform all recommended maintenance. Never exceed load limits (➤ P. 15), and do not modify your motorcycle or install accessories that would make your motorcycle unsafe (➤ P. 14).

Safety Guidelines

If You are Involved in a Crash

Personal safety is your first priority. If you or anyone else has been injured, take time to assess the severity of the injuries and whether it is safe to continue riding. Call for emergency assistance if needed. Also follow applicable laws and regulations if another person or vehicle is involved in the crash.

If you decide to continue riding, first turn the ignition switch to the **O** (Off) position, and evaluate the condition of your motorcycle. Inspect for fluid leaks, check the tightness of critical nuts and bolts, and check the handlebar, control levers, brakes, and wheels. Ride slowly and cautiously.

Your motorcycle may have suffered damage that is not immediately apparent. Have your motorcycle thoroughly checked at a qualified service facility as soon as possible.

Carbon Monoxide Hazard

Exhaust contains poisonous carbon monoxide, a colourless, odorless gas. Breathing carbon monoxide can cause loss of consciousness and may lead to death.

If you run the engine in confined or even partly enclosed area, the air you breathe could contain a dangerous amount of carbon monoxide. Never run your motorcycle inside a garage or other enclosure.

⚠WARNING

Running the engine of your motorcycle while in an enclosed or even partially enclosed area can cause a rapid build-up of toxic carbon monoxide gas.

Breathing this colourless, odorless gas can quickly cause unconsciousness and lead to death.

Only run your motorcycle's engine when it is located in a well ventilated area outdoors.

Image Labels

Image Labels

Motorcycle Safety

The following pages describe the label meanings. Some labels warn you of potential hazards that could cause serious injury. Others provide important safety information. Read this information carefully and don't remove the labels.

If a label comes off or becomes hard to read, contact your dealer for a replacement.

There is a specific symbol on each label. The meanings of each symbol and label are as follows.



Read instructions contained in Owner's Manual carefully.



Read instructions contained in Shop Manual carefully. In the interest of safety, take the motorcycle to be serviced only by your dealer.



DANGER (with RED background)

You WILL be KILLED or SERIOUSLY HURT if you don't follow instructions.

WARNING (with ORANGE background)

You CAN be KILLED or SERIOUSLY HURT if you don't follow instructions.

CAUTION (with YELLOW background)

You CAN be HURT if you don't follow instructions.

Image Labels



BATTERY LABEL DANGER

- Keep flame and spark away from the battery. Battery produce explosive gas that can cause explosion.
- Wear the eye protection and rubber gloves when handling the battery, or you can get burned or lose your eyesight by the battery electrolyte.
- Do not allow children and other people to touch a battery unless they understand proper handling and hazards of the battery very well.
- Handle the battery electrolyte with extreme care as it contains dilute sulfuric acid. Contact with your skin or eyes can burn you or cause loss of your eyesight.
- Read this manual carefully and understand it before handling the battery. Neglect of the instructions can cause personal injury and damage to the motorcycle.
- Do not use a battery with the electrolyte at or below the lower level mark. It can explode causing serious injury.

Continued 7

Image Labels



RADIATOR CAP LABEL DANGER

NEVER OPEN WHEN HOT.

Hot coolant will scald you.

Relief pressure valve begins to open at **1.1 kgf/cm²**.

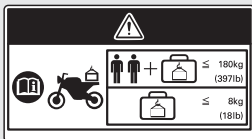

ACCESSORIES AND LOADING WARNING LABEL WARNING

ACCESSORIES AND LOADING

- The safety stability and handling of this motorcycle may be affected by the addition of accessories and luggage.
- Read carefully the instructions contained in user's manual and installation guide before installing any accessory.
- The total weight of accessories and luggage added to rider's and passenger's weight should not exceed **180 kg (397 lb)**, which is the maximum weight capacity.
- The luggage weight must not exceed **8 kg (18 lb)** under any circumstances.
- The fitting of large fork-mounted or large handlebar mounted fairing is not recommended.

Image Labels

Motorcycle Safety



REAR CUSHION LABEL

GAS FILLED

Do not open. Do not heat.

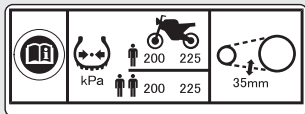

TYRE INFORMATION & DRIVE CHAIN LABEL

Cold tyre pressure:

[Driver only]

Front **200 kPa (2.00 kgf/cm², 29 psi)**

Rear **225 kPa (2.25 kgf/cm², 33 psi)**

[Driver and passenger]

Front **200 kPa (2.00 kgf/cm², 29 psi)**

Rear **225 kPa (2.25 kgf/cm², 33 psi)**

Keep chain adjusted and lubricated.

Freeplay **30 - 40 mm (1.2 - 1.6 in)**



or



SAFETY REMINDER LABEL

For your protection, always wear helmet, protective apparel.

FUEL LABEL

Unleaded petrol only

ETHANOL up to 10 % by volume

Safety Precautions

Safety Precautions

- Ride cautiously and keep your hands on the handlebar and feet on the footpegs.
- Keep passenger's hands onto the seat strap or your waist, passenger's feet on the footpegs while riding.
- Always consider the safety of your passenger, as well as other drivers and riders.

Protective Apparel

Make sure that you and any passenger are wearing an approved motorcycle helmet, eye protection, and high-visibility protective clothing. Ride defensively in response to weather and road conditions.

■ **Helmet**

Safety-standard certified, high-visibility, correct size for your head

- Must fit comfortably but securely, with the chin strap fastened.

- Face shield with unobstructed field of vision or other approved eye protection

⚠ WARNING

Not wearing a helmet increases the chance of serious injury or death in a crash.

Make sure that you and any passenger always wear an approved helmet and protective apparel.

■ **Gloves**

Full-finger leather gloves with high abrasion resistance

■ **Boots or Riding Shoes**

Sturdy boots with non-slip soles and ankle protection

■ **Jacket and Trousers**

Protective, highly visible, long-sleeved jacket and durable trousers for riding (or a protective suit)

Riding Precautions

Riding Precautions

Running-in Period

During the first 500 km (300 miles) of running, follow these guidelines to ensure your motorcycle's future reliability and performance.

- Avoid full-throttle starts and rapid acceleration.
- Avoid hard braking and rapid down-shifts.
- Ride conservatively.

Brakes

Observe the following guidelines:

- Avoid excessively hard braking and downshifting.
 - ▶ Sudden braking can reduce the motorcycle's stability.
 - ▶ Where possible, reduce speed before turning; otherwise you risk sliding out.

- Exercise caution on low traction surfaces.
 - ▶ The tyres slip more easily on such surfaces and braking distances are longer.
- Avoid continuous braking.
 - ▶ Repeated braking, such as when descending long, steep slopes can seriously overheat the brakes, reducing their effectiveness. Use engine braking with intermittent use of the brakes to reduce speed.
- For full braking effectiveness, operate both the front and rear brakes together.

Riding Precautions

■ Anti-lock Brake System (ABS)

This model is equipped with an Anti-lock Brake System (ABS) designed to help prevent the brakes from locking up during hard braking. The ABS functions with information provided by the IMU (Inertia Measurement Unit).

- ABS does not reduce braking distance. In certain circumstances, ABS may result in a longer stopping distance.
- ABS does not function at speeds below 10 km/h (6 mph).
- The brake lever and pedal may recoil slightly when applying the brakes. This is normal.
- Always use the recommended front/rear tyres and sprockets to ensure correct ABS operation.

■ Engine Braking

Engine braking helps slow your motorcycle down when you release the throttle. For further slowing action, downshift to a lower gear. Use engine braking with intermittent use of the brakes to reduce speed when descending long, steep slopes.

■ Wet or Rainy Conditions

Road surfaces are slippery when wet, and wet brakes further reduce braking efficiency. Exercise extra caution when braking in wet conditions.

If the brakes get wet, apply the brakes while riding at low speed to help them dry.



Riding Precautions

Parking

- Park on a firm, level surface.
- If you must park on a slight incline or loose surface, park so that the motorcycle cannot move or fall over.
- Make sure that high-temperature parts cannot come into contact with flammable materials.
- Do not touch the engine, muffler, brakes and other high-temperature parts until they cool down.
- To reduce the likelihood of theft, always lock the handlebar and remove the key when leaving the motorcycle unattended. Use of an anti-theft device is also recommended.

Parking with the Side Stand

1. Stop the engine.
2. Push the side stand down.
3. Slowly lean the motorcycle to the left until its weight rests on the side stand.

4. Turn the handlebar fully to the left.
 - ▶ Turning the handlebar to the right reduces stability and may cause the motorcycle to fall.
5. Turn the ignition switch to the  (Lock) position and remove the key.  P. 42

Refuelling and Fuel Guidelines

Follow these guidelines to protect the engine, fuel system and catalytic converter:

- Use only unleaded petrol.
- Use recommended octane number. Using lower octane petrol will result in decreased engine performance.
- Do not use fuels containing a high concentration of alcohol.  P. 127
- Do not use stale or contaminated petrol or an oil/petrol mixture.
- Avoid getting dirt or water in the fuel tank.

Accessories & Modifications

Motorcycle Safety

Accessories & Modifications

We strongly advise that you do not add any accessories that were not specifically designed for your motorcycle by Honda or make modifications to your motorcycle from its original design. Doing so can make it unsafe. Modifying your motorcycle may also void your warranty and make your motorcycle illegal to operate on public roads and highways. Before deciding to install accessories on your motorcycle be certain the modification is safe and legal.

⚠️ WARNING

Improper accessories or modifications can cause a crash in which you can be seriously hurt or killed.

Follow all instructions in this owner's manual regarding accessories and modifications.

Do not pull a trailer with, or attach a sidecar to, your motorcycle. Your motorcycle was not designed for these attachments, and their use can seriously impair your motorcycle's handling.

Loading

- Carrying extra weight affects your motorcycle's handling, braking and stability. Always ride at a safe speed for the load you are carrying.
- Avoid carrying an excessive load and keep within specified load limits.

Maximum weight capacity / Maximum luggage weight  P. 129

- Tie all luggage securely, evenly balanced and close to the centre of the motorcycle.
- Do not place objects near the lights or the muffler.

WARNING

Overloading or improper loading can cause a crash and you can be seriously hurt or killed.

Follow all load limits and other loading guidelines in this manual.

Parts Location

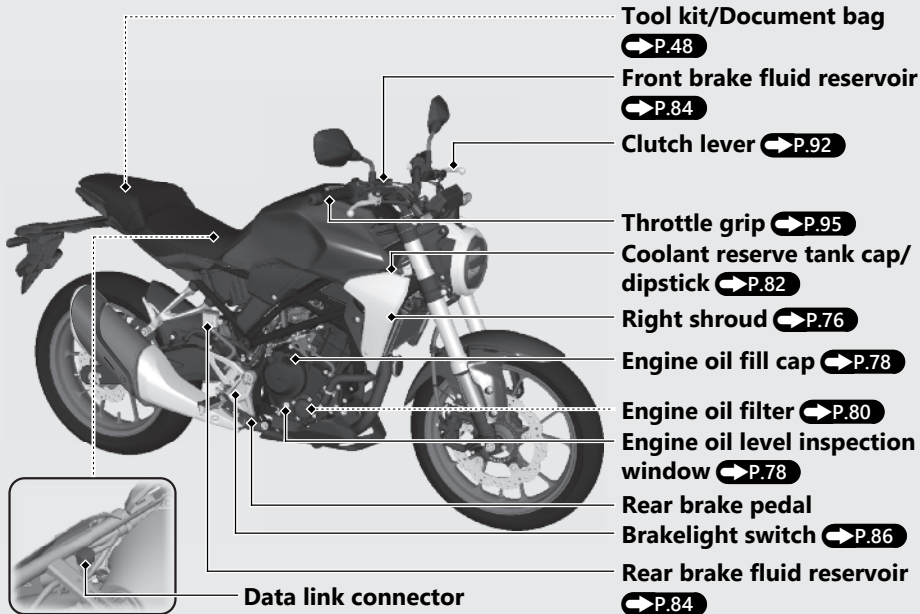

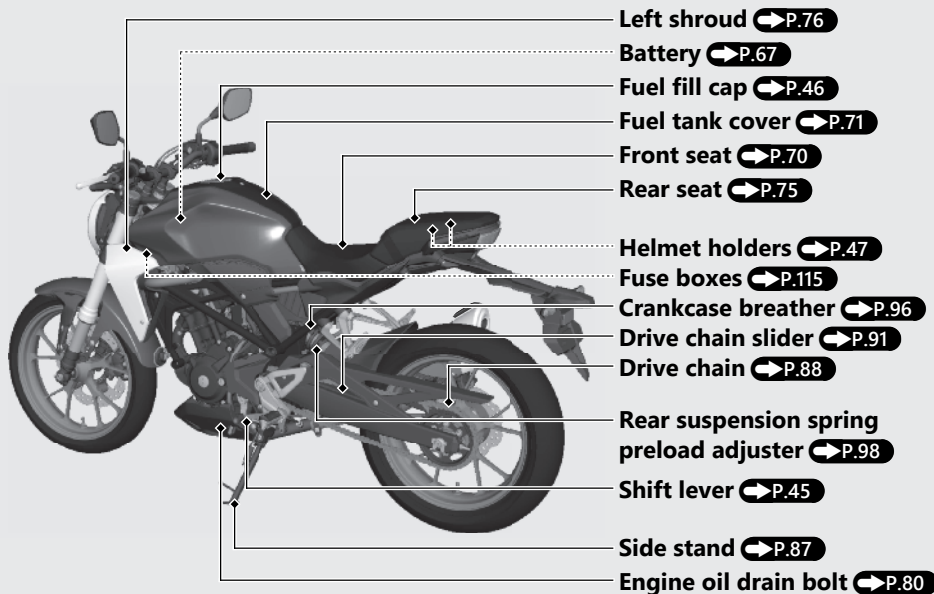

Instruments

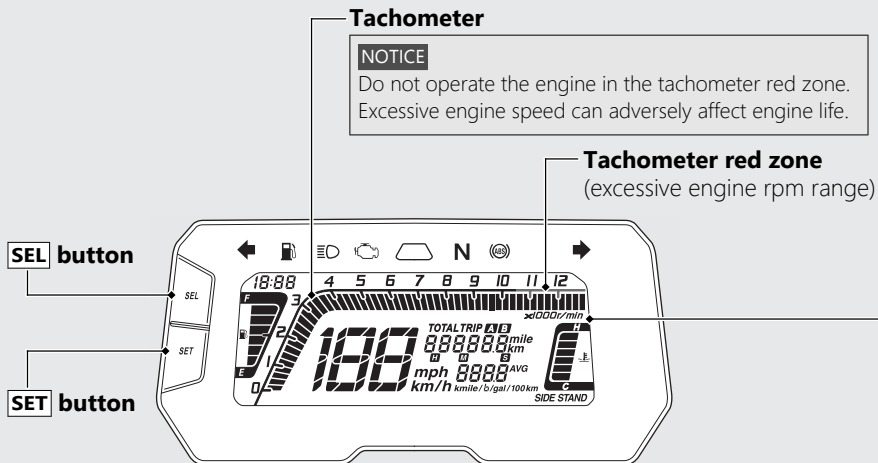

Display Check

When the ignition switch is turned to the **I** (On) position, all the mode and digital segments will show. If any part of these displays does not come on when it should, have your dealer check for problems.

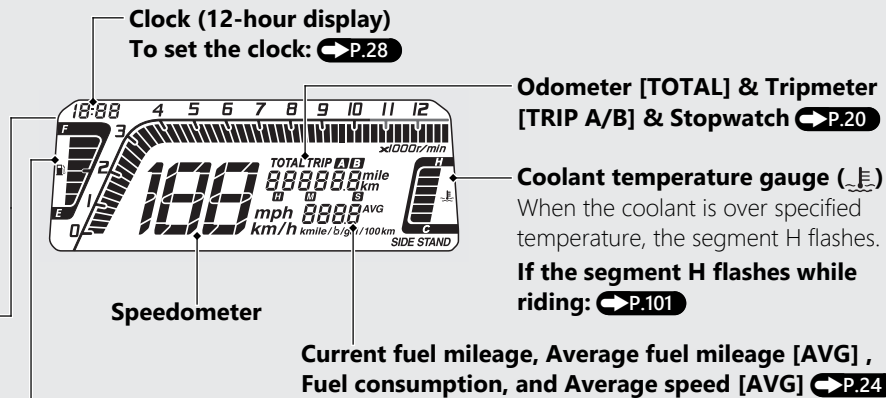

Fuel gauge

Remaining fuel when only 1st (E) segment starts flashing: approximately 1.9 L (0.50 US gal, 0.42 Imp gal)

If the fuel gauge indicator flashes in a repeat pattern or turns off: ➔ P.104



Instruments *(Continued)*

Odometer [TOTAL] & Tripmeter [TRIP A/B] & Stopwatch

The **[SEL]** button switches between the odometer, tripmeter A, tripmeter B and stopwatch.

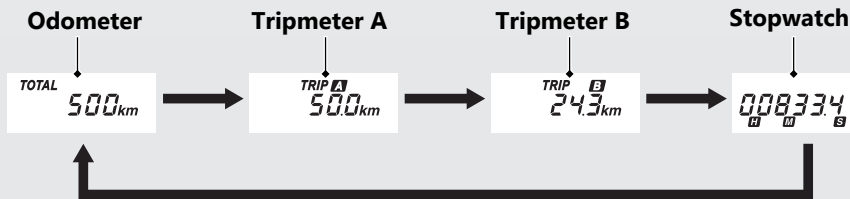

| Odometer [TOTAL]

Total distance ridden. When “-----” is displayed, go to your dealer for service.

| Tripmeter [TRIP A/B]

Distance ridden since tripmeter was reset. When “-.-.-.-” is displayed, go to your dealer for service.

To reset the tripmeter:  **P.22**

| Stopwatch

Shows elapsed time since the **SET** button was pushed to start the measurement.

Display range:

0H00M00.0S - 9H59M59.9S

- Above 9H59M59.9S back to 0H00M00.0S

To use the stopwatch:  **P.23**

Instruments *(Continued)*

To reset the tripmeter [TRIP A/B], average fuel mileage [AVG], fuel consumption and average speed [AVG]

To reset the tripmeter A, average fuel mileage A, fuel consumption A and average speed A (these are based on tripmeter A) together, press and hold the **[SEL]** button while tripmeter A is displayed.

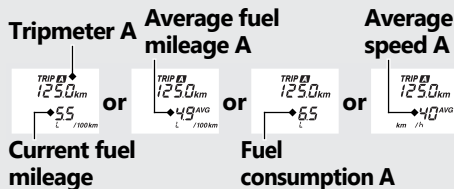

When they are reset, reset display appears at each indication. Then, the display returns to the last selected indication.



To reset the tripmeter B, average fuel mileage B, fuel consumption B and average speed B (these are based on tripmeter B) together, press and hold the **[SEL]** button while tripmeter B is displayed.

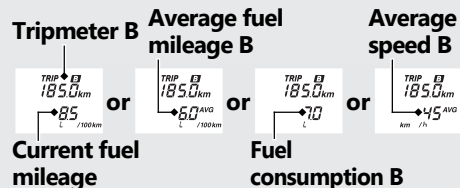



When they are reset, reset display appears at each indication. Then, the display returns to the last selected indication.



Stopwatch

To Measure the Time

- 1 Select the stopwatch. 
- 2 To start measurement, press the **SET** button.
 - ▶ The measurement keeps going, if you change an item while measuring.
- 3 To finish measurement, press the **SET** button.
 - ▶ The measurement can also be finished by turning the ignition switch to the  (Off) position.

SEL button

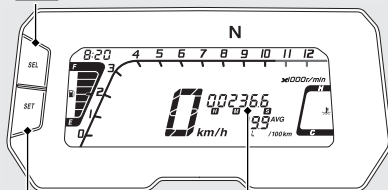

SET button

Stopwatch

To Restart the Measurement

Press the **SET** button again. The stopwatch restarts measurement.

To Reset the Measured Value

Press and hold the **SEL** button when the stopwatch is displayed and also the measurement is finished.

Instruments *(Continued)*

Current fuel mileage, Average fuel mileage [AVG], Fuel consumption, and Average speed [AVG]

The **SET** button switches between the current fuel mileage, average fuel mileage, fuel consumption and average speed.

- ▶ The items cannot be switched by the **SET** button if the stopwatch is displayed.

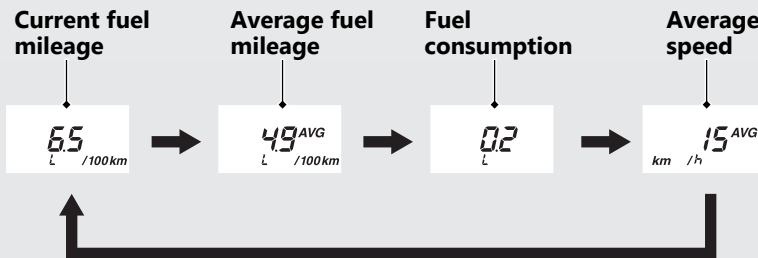

Current fuel mileage

Displays the current instant fuel mileage.
Display range: 0.0 to 299.9 L/100km (km/L, mile/gal or mile/L)

- More than 299.9 L/100km (km/L, mile/gal or mile/L): "299.9" is displayed.
- When your speed is less than 6 km/h (4 mph): "---" is displayed.

When "---" is displayed except for the above-mentioned cases, go to your dealer for service.

Average fuel mileage [AVG]

Displays the average fuel mileage since the selected tripmeter was reset.

The average fuel mileage will be calculated based on value displayed on the tripmeter (A or B) selected.

Also, the average fuel mileage for tripmeter A will be displayed when the odometer, tripmeter A, and stopwatch are selected.

Display range: 0.0 to 299.9 L/100km (km/L, mile/gal or mile/L)

- More than 299.9 L/100km (km/L, mile/gal or mile/L): "299.9" is displayed.
- When the tripmeter A or B is reset: "---" is displayed.

When "---" is displayed except for the above-mentioned cases, go to your dealer for service.

To reset the average fuel mileage:

 **P.22**

Continued 25

Instruments *(Continued)*

Fuel consumption

Displays the fuel consumption since the selected tripmeter was reset.

The fuel consumption will be calculated based on value displayed on the tripmeter (A or B) selected.

Also, the fuel consumption for tripmeter A will be displayed when the odometer, tripmeter A, and stopwatch are selected.

Display range: 0.0 to 299.9 L (litres) or 0.0 to 299.9 gal (gallon)

- More than 299.9 L (litres) or 299.9 gal (gallon): "299.9" is displayed.

When "---" is displayed, go to your dealer for service.

To reset the fuel consumption: ➡ P.22

Average speed

Displays the average speed since the selected tripmeter was reset.

The average speed will be calculated based on value displayed on the tripmeter (A or B) selected.

Also, the average speed for tripmeter A will be displayed when the odometer, tripmeter A, and stopwatch are selected.

Display range: 0 to 199 km/h (0 to 124 mile/h)

- Initial display: "---" is displayed.
- When your motorcycle has travelled less than 0.2 km (0.12 mile) since the engine was started: "---" is displayed.
- When your motorcycle operating time is less than 30 seconds since the engine was started: "---" is displayed.

When "---" is displayed except for the above-mentioned cases, go to your dealer for service.

To reset the average speed: ➡ P.22

Display Setting Setting Mode A

Following items can be changed sequentially. **➡P.28**

- Clock setting
- Backlight brightness adjustment
- Changing the speed and mileage unit
- Changing the fuel mileage meter unit

Setting Mode B

Following items can be changed sequentially. **➡P.31**

- Setting of REV indicator
(lighting RPM setting, lighting interval RPM setting and brightness adjustment)
- Changing of tachometer display mode



Instruments *(Continued)*

Setting Mode A

If the buttons are not pressed for about 30 seconds, the control is automatically switched from the setting mode to the ordinary display.

If the buttons are not pressed for about 30 seconds, items in the process of being set will be discarded and only items where settings have been finalised will be applied. Only if the ignition switch is turned to the  (Off) position, items in the process of being set and those that are finalised will be applied.

1 Clock setting:

- ① Turn the ignition switch to the  (On) position.
- ② Select the odometer, tripmeter A or tripmeter B. 
- ③ Press and hold **SEL** and **SET** buttons until the hour digits start flashing.



- ④ Press **SEL** button until the desired hour is displayed.
 - ▶ Press and hold **SEL** button to advance the hour fast.



- 5 Press **SET** button. The minute digits start flashing.



- 6 Press **SEL** button until the desired minute is displayed.

- ▶ Press and hold **SEL** button to advance the minute fast.

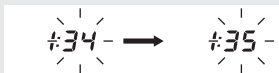

- 7 Press **SET** button. The clock is set, and then the display moves to the backlight brightness adjustment.

2 Backlight brightness adjustment:

You can adjust the brightness to one of five levels.

- 1 Press **SEL** button. The brightness is switched.



- 2 Press **SET** button. The backlight is set, and then the display moves to the changing the speed and mileage unit. The speed and mileage unit will start flashing.

Instruments (Continued)**3 Changing the speed and mileage unit:**

- 1 Press **SEL** button to select either "km/h" and "km" or "mph" and "mile".



- 2 Press **SET** button. The speed and mileage unit is set, and then the display moves to the changing the fuel mileage meter unit.

4 Changing the fuel mileage meter unit:

- 1 When the "km/h" for speed and "km" for mileage are selected

Press **SEL** button to select "km/L" or "L/100km".

When the "mph" for speed and "mile" for mileage are selected

Press **SEL** button to select "mile/L" or "mile/gal".

▶ When "mile/gal" is selected, the unit of the fuel consumption is changed to "gal".

- 2 Press **SET** button. The fuel mileage meter unit is set, and then the display moves to the ordinary display.

Setting Mode B

If the buttons are not pressed for about 30 seconds, the control is automatically switched from the setting mode to the ordinary display.

If the buttons are not pressed for about 30 seconds, items in the process of being set will be discarded and only items where settings have been finalised will be applied. Only if the ignition switch is turned to the  (Off) position, items in the process of being set and those that are finalised will be applied.

1 Setting of REV indicator:

You can change the setting of the REV indicator.

REV indicator is blinking while setting.

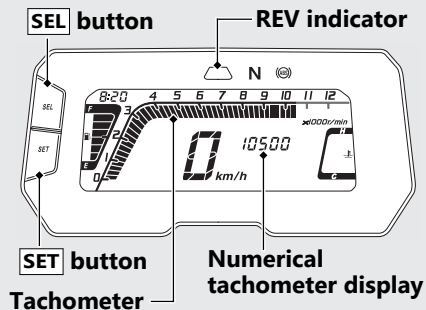

Instruments *(Continued)*

- 1 To change the setting mode B, turn the ignition switch to the I (On) position while pressing **SEL** button until the display check is finished. The blinking of bar segment in the tachometer shows the currently applied REV indicator lighting RPM, and the numerical tachometer display shows it.
 - ▶ Tachometer bar segment is displayed as conventional display, regardless of set up display method.
- 2 Each time **SEL** button is pressed, the lighting RPM set value increase by 250 r/min (rpm) (one segment). When the lighting RPM set value exceeds the allowable range, the lighting RPM set value automatically returns to 4,000 r/min (rpm).
 - ▶ Press and hold **SEL** button to advance the lighting RPM set value fast.

Available Setting Range
4,000 -to- 10,500 r/min (rpm)

- 3 Press **SET** button. The REV indicator lighting RPM is set, and then the display moves to the setting of REV indicator lighting interval RPM.

At the same time, the blinking bar segment shows the currently applied setting originated from the REV indicator lighting RPM and the numerical tachometer display shows the REV indicator lighting interval RPM.

- 4 Each time **SEL** button is pressed, the number of REV indicator lighting interval RPM is switched among 0 r/min (rpm), 250 r/min (rpm) and 500 r/min (rpm) in this order.

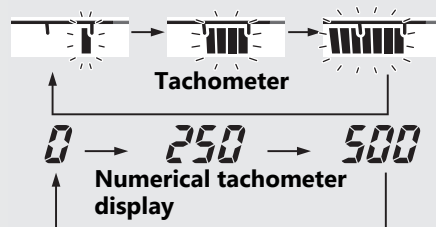

Instruments *(Continued)*

Ex When REV indicator lighting RPM is setting 10,000 r/min (rpm) and REV indicator lighting interval RPM is 250 r/min (rpm).

REV indicator	r/min (rpm)
Blinking (2 times/second)	9,250 r/min (rpm)
Blinking (5 times/second)	9,500 r/min (rpm)
Blinking (10 times/second)	9,750 r/min (rpm)
Lighting	10,000 r/min (rpm)

If the REV indicator lighting interval RPM is 0, the REV indicator starts to light when reaching to the REV indicator lighting RPM.

- 5 Press **SET** button. The REV indicator lighting interval RPM is set, and then the display moves to the brightness adjustment of the REV indicator.

The REV indicator switches from blinking to lighting.

- 6 Press **SEL** button. The brightness is switched.

▶ You can adjust the brightness to one of five levels.



- 7 Press **SET** button. The brightness of the REV indicator is set, and then the display moves to the display setting of the tachometer.

2 Changing of tachometer display mode:

You can change the display mode of the tachometer.

- ① Press **SEL** button to switch the display mode of tachometer.
- ② Press **SET** button. The currently selected display mode is set, and then the display moves to the ordinary display.

Conventional display

Shows the engine RPM on the tachometer bar segment.

Peak hold display

Shows the engine RPM on the tachometer bar segment and peak hold segment. The peak hold segment keeps to show the maximum engine RPM temporarily.

Ex Engine revolutions per minutes
10,500 r/min (rpm)

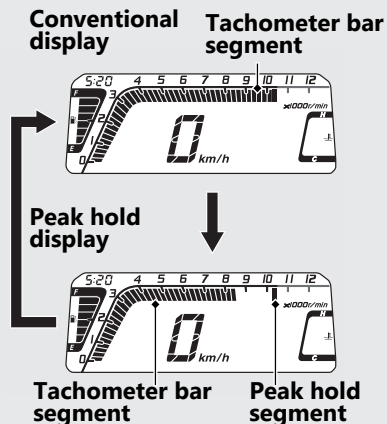

Indicators

If one of these indicators does not come on when it should, have your dealer check for problems.

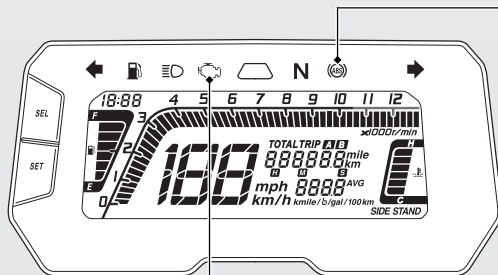

ABS (Anti-lock Brake System) indicator

Comes on when the ignition switch is turned to the **I** (On) position. Goes off when your speed reaches approximately 10 km/h (6 mph).

If it comes on while riding:

 **P.103**

PGM-FI (Programmed Fuel Injection) malfunction indicator lamp (MIL)

Comes on briefly when the ignition switch is turned to the **I** (On) position with the engine stop switch in the **O** (Run) position.

If it comes on while engine is running:

 **P.102**

REV indicator



High beam indicator

Left turn signal indicator

N Neutral indicator

Comes on when the transmission is in Neutral.

Right turn signal indicator

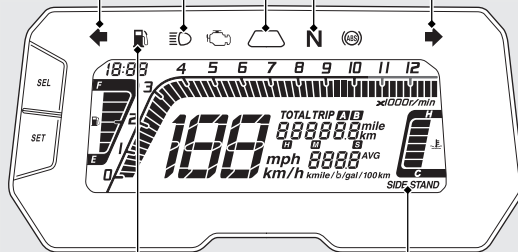

Low fuel indicator

Comes on when there is only reserve fuel left in the fuel tank. Remaining fuel when low fuel indicator comes on: 1.9 L (0.50 US gal, 0.42 Imp gal)

SIDE STAND indicator

Comes on when the side stand is lowered.

Indicators *(Continued)***REV Indicator**

- Comes on briefly when the ignition switch is turned to the **I** (On) position.

Initial setting

Lighting RPM: 8,000 r/min (rpm)



Interval RPM: 250 r/min (rpm)

REV indicator	r/min (rpm)
Blinking (2 times/second)	7,250 r/min (rpm)
Blinking (5 times/second)	7,500 r/min (rpm)
Blinking (10 times/second)	7,750 r/min (rpm)
Lighting	8,000 r/min (rpm)

▶ Setting of REV indicator:  **P.31**

Switches

Headlight dimmer switch

-  : High beam
-  : Low beam



Horn button



Turn signal switch

- ▶ Pressing the switch turns the turn signal off.



PASS Passing light control switch

Flashes the high beam headlight.



Start button

Engine stop switch

Should normally remain in the  (Run) position.

- ▶ In an emergency, switch to the  (Stop) position (the starter motor will not operate) to stop the engine.

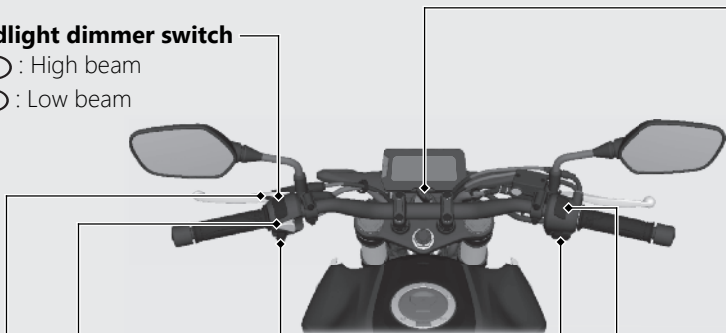

Ignition switch

Switches the electrical system on/off, locks the steering.

- ▶ Key can be removed when in the ○ (Off) or  (Lock) position.

 **(On)**
Turns electrical system on for starting/riding.

 **(Off)**
Turns engine off.

 **(Lock)**
Locks steering.

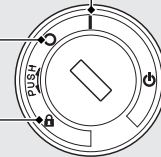

Switches *(Continued)*

Steering Lock

Lock the steering when parking to help prevent theft.

A U-shaped wheel lock or similar device is also recommended.

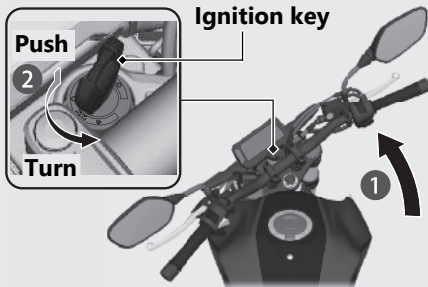

Locking

- 1 Turn the handlebar all the way to the left.
- 2 Push the ignition key down, and turn the ignition switch to the  (Lock) position.
 - ▶ Jiggle the handlebar if the lock is difficult to engage.
- 3 Remove the ignition key.

Unlocking

Insert the key, push it in, and turn the ignition switch to the  (Off) position.

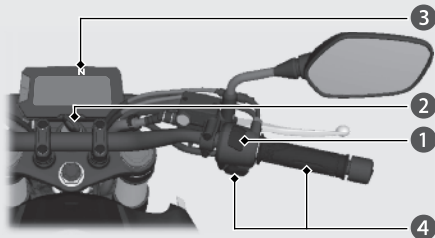

Starting the Engine

Start your engine using the following procedure, regardless of whether the engine is cold or warm.



NOTICE

- If the engine does not start within 5 seconds, turn the ignition switch to the  (Off) position and wait 10 seconds before trying to start the engine again to recover battery voltage.
- Extended fast idling and revving the engine can damage the engine, and the exhaust system.

- 1 Make sure the engine stop switch is in the  (Run) position.
- 2 Turn the ignition switch to the  (On) position.
- 3 Shift the transmission to Neutral ( indicator to come on). Alternatively, pull in the clutch lever to start your motorcycle with the transmission in gear so long as the side stand is raised.
- 4 With the throttle completely closed, press the start button.
 - ▶ If you cannot start the engine, open the throttle slightly (about 3 mm (0.1 in), without freewheel) and press the start button.

About 3 mm (0.1 in), without freewheel

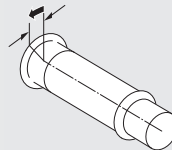

Starting the Engine *(Continued)*

If the engine does not start:

- ① Open the throttle fully and press the start button for 5 seconds.
- ② Repeat the normal starting procedure.
- ③ If the engine starts, open the throttle slightly if idling is unstable.
- ④ If the engine does not start, wait 10 seconds before trying step ① & ② again.

If Engine Will Not Start ➡ P.100

Shifting Gears

Your motorcycle transmission has 6 forward gears in a one-down, five-up shift pattern.

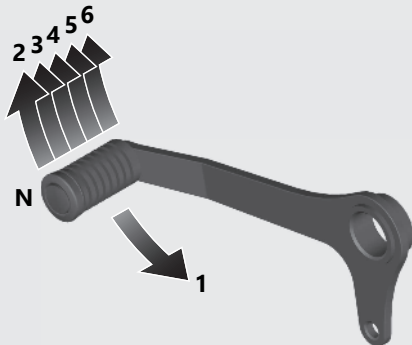

If you put the motorcycle in gear with the side stand down, the engine will shut off.

Refuelling

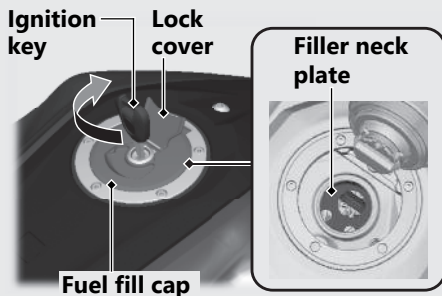

Do not fill with fuel above the filler neck plate.

Fuel type: Unleaded petrol only

Fuel octane number: Your motorcycle is designed to use Research Octane Number (RON) 91 or higher.

Tank capacity: 10.1 L (2.67 US gal, 2.22 Imp gal)

Refuelling and Fuel Guidelines ➔ P.13

Opening the Fuel Fill Cap

Open the lock cover, insert the ignition key, and turn it clockwise to open the fuel fill cap.

Closing the Fuel Fill Cap

- 1 After refuelling, push the fuel fill cap closed until it locks.
- 2 Remove the ignition key and close the lock cover.
 - ▶ The ignition key cannot be removed if the fuel fill cap is not locked.

⚠WARNING

Petrol is highly flammable and explosive. You can be burned or seriously injured when handling fuel.

- Stop the engine, and keep heat, sparks, and flame away.
- Handle fuel only outdoors.
- Wipe up spills immediately.

Storage Equipment

Helmet Holder

The helmet holders are located under the rear seat.

Helmet holders

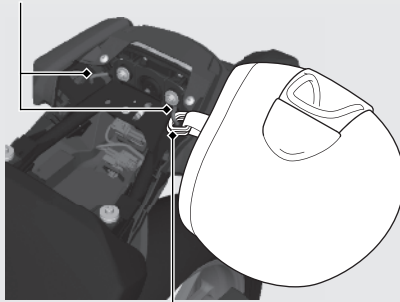

Helmet D-ring

► Use the helmet holder only when parked.

▮ **Removing the Rear Seat** ➡ P.75

⚠ WARNING

Riding with a helmet attached to the holder can interfere with your ability to safely operate the motorcycle and could lead to a crash in which you can be seriously hurt or killed.

Use the helmet holder only while parked. Do not ride with a helmet secured by the holder.

Storage Equipment *(Continued)*

Tool Kit/Document Bag

The tool kit and document bag are located underside of the rear seat by the rubber strap.

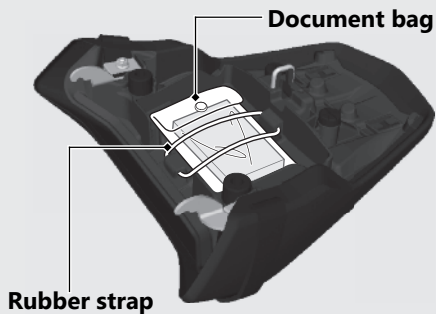

The tool kit is stored below the document bag.

- ▶ Put the tool kit in inside of the ribs.

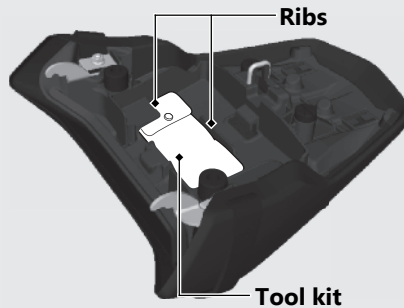

Removing the Rear Seat  P.75

Maintenance

Please read "Importance of Maintenance" and "Maintenance Fundamentals" carefully before attempting any maintenance. Refer to "Specifications" for service data.

Importance of Maintenance	P. 50	Brakes	P. 84
Maintenance Schedule	P. 51	Side Stand	P. 87
Maintenance Fundamentals	P. 54	Drive Chain	P. 88
Tool	P. 66	Clutch	P. 92
Removing & Installing Body Components ..	P. 67	Throttle	P. 95
Battery	P. 67	Crankcase Breather	P. 96
Clip	P. 69	Other Adjustments	P. 97
Front Seat	P. 70	Adjusting the Headlight Aim	P. 97
Fuel Tank Cover Assembly	P. 71	Adjusting the Rear Suspension	P. 98
Fuel Tank Maintenance Position	P. 73		
Rear Seat	P. 75		
Shroud	P. 76		
Engine Oil	P. 78		
Coolant	P. 82		

Importance of Maintenance

Importance of Maintenance

Keeping your motorcycle well-maintained is absolutely essential to your safety and to protect your investment, obtain maximum performance, avoid breakdowns, and reduce air pollution. Maintenance is the owner's responsibility. Be sure to inspect your motorcycle before each ride, and perform the periodic checks specified in the Maintenance Schedule. ➤ P. 51

⚠ WARNING

Improperly maintaining your motorcycle or failing to correct a problem before you ride can cause a crash in which you can be seriously hurt or killed.

Always follow the inspection and maintenance recommendations and schedules in this owner's manual.

Maintenance Safety

Always read the maintenance instructions before you begin each task, and make sure that you have the tools, parts, and skills required. We cannot warn you of every conceivable hazard that can arise in performing maintenance. Only you can decide whether or not you should perform a given task.

Follow these guidelines when performing maintenance.

- Stop the engine and remove the key.
- Place your motorcycle on a firm, level surface using the side stand or a maintenance stand to provide support.
- Allow the engine, muffler, brakes, and other high-temperature parts to cool before servicing as you can get burned.
- Run the engine only when instructed, and do so in a well-ventilated area.

Maintenance Schedule

The maintenance schedule specifies the maintenance requirements necessary to ensure safe, dependable performance, and proper emission control.

Maintenance work should be performed in accordance with Honda's standards and specifications by properly trained and equipped technicians. Your dealer meets all of these requirements. Keep an accurate record of maintenance to help ensure that your motorcycle is properly maintained. Make sure that whomever performs the maintenance completes this record.

All scheduled maintenance is considered a normal owner operating cost and will be charged to you by your dealer. Retain all receipts. If you sell the motorcycle, these receipts should be transferred with the motorcycle to the new owner.

Honda recommends that your dealer should road test your motorcycle after each periodic maintenance is carried out.

Maintenance Schedule

Items	Pre-ride Check ☑ P. 54	Frequency *1					Annual Check	Regular Replace	Refer to page	
		× 1,000 km	1	12	24	36				48
		× 1,000 mi	0.6	8	16	24				32
Fuel Line	🔧			I	I	I	I	I		-
Fuel Level		I								46
Throttle Operation	🔧	I		I	I	I	I	I		95
Air Cleaner *2	🔧					R		R		65
Crankcase Breather *3				C	C	C	C			96
Spark Plug	🔧				I			R		-
Valve Clearance	🔧				I			I		-
Engine Oil		I		R	R	R	R	R	R	78
Engine Oil Filter				R		R		R		80
Engine Idle Speed	🔧			I	I	I	I	I		-
Radiator Coolant *4		I		I	I	I	I	I	3 Years	82
Cooling System	🔧			I	I	I	I	I		-
Secondary Air Supply System	🔧				I			I		-
Evaporative Emission Control System	🔧				I			I		-

Maintenance Level

- 🔧 : Intermediate. We recommend service by your dealer, unless you have the necessary tools and are mechanically skilled. Procedures are provided in an official Honda Shop Manual.
- 🔧 : Technical. In the interest of safety, have your motorcycle serviced by your dealer.

Maintenance Legend

- I : Inspect (clean, adjust, lubricate, or replace, if necessary)
- C : Clean
- R : Replace
- L : Lubricate

Maintenance Schedule

Items	Pre-ride Check P. 54	Frequency *1					Annual Check	Regular Replace	Refer to page	
		× 1,000 km	1	12	24	36				48
		× 1,000 mi	0.6	8	16	24				32
Drive Chain	☑	Every 1,000 km (600 mi): ☑ ☑							88	
Drive Chain Slider			☑	☑	☑	☑			91	
Brake Fluid *4	☑		☑	☑	☑	☑	☑	2 Years	84	
Brake Pads Wear	☑		☑	☑	☑	☑	☑		85	
Brake System			☑	☑	☑	☑	☑		54	
Brakelight Switch			☑	☑	☑	☑	☑		86	
Headlight Aim			☑	☑	☑	☑	☑		97	
Lights/Horn	☑								–	
Engine Stop Switch	☑								40	
Clutch System	☑		☑	☑	☑	☑	☑		92	
Side Stand	☑		☑	☑	☑	☑	☑		87	
Suspension	↗		☑	☑	☑	☑	☑		–	
Nuts, Bolts, Fasteners	↗		☑	☑	☑	☑	☑		–	
Wheels/Tyres	✂	☑	☑	☑	☑	☑	☑		62	
Steering Head Bearings	✂		☑	☑	☑	☑	☑		–	

Notes:

*1 : At higher odometer reading, repeat at the frequency interval established here.

*2 : Service more frequently when riding in unusually wet or dusty areas.

*3 : Service more frequently when riding in rain or at full throttle.











*4 : Replacement requires mechanical skill.

Maintenance Fundamentals

Pre-ride Inspection

To ensure safety, it is your responsibility to perform a pre-ride inspection and make sure that any problem you find is corrected. A pre-ride inspection is a must, not only for safety, but because having a breakdown, or even a flat tyre, can be a major inconvenience.

Check the following items before you get on your motorcycle:

- Fuel level - Fill fuel tank when necessary.  P. 46
- Throttle - Check for smooth opening and full closing in all steering positions.  P. 95
- Engine oil level - Add engine oil if necessary. Check for leaks.  P. 78
- Coolant level - Add coolant if required. Check for leaks.  P. 82
- Drive chain - Check condition and slack, adjust and lubricate if necessary.  P. 88
- Brakes - Check operation;
Front and Rear: check brake fluid level and pads wear.  P. 84,  P. 85
- Lights and horn - Check that lights, indicators and horn function properly.
- Engine stop switch - Check for proper function.  P. 40
- Clutch - Check operation;
Adjust freeplay if necessary.  P. 92
- Side stand ignition cut-off system - Check for proper function.  P. 87
- Wheels and tyres - Check condition, air pressure and adjust if necessary.  P. 62

Replacing Parts

Always use Honda Genuine Parts or their equivalents to ensure reliability and safety. When ordering coloured components, specify the model name, colour, and code mentioned on the colour label.

The colour label is attached to the rear fender under the rear seat.  P. 75

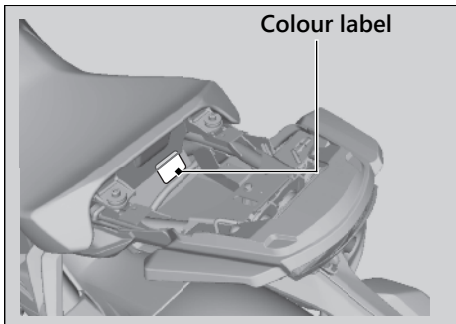

WARNING

Installing non-Honda parts may make your motorcycle unsafe and cause a crash in which you can be seriously hurt or killed.

Always use Honda Genuine Parts or equivalents that have been designed and approved for your motorcycle.

Maintenance Fundamentals

Battery

Your motorcycle has a maintenance-free type battery. You do not have to check the battery electrolyte level or add distilled water. Clean the battery terminals if they become dirty or corroded.

Do not remove the battery cap seals. There is no need to remove the cap when charging.

NOTICE

Your battery is a maintenance-free type and can be permanently damaged if the cap strip is removed.



This symbol on the battery means that this product must not be treated as household waste.

NOTICE

An improperly disposed of battery can be harmful to the environment and human health. Always confirm local regulations for proper battery disposal instruction.

What to do in an emergency

If any of the following occur, immediately see your doctor.

- Electrolyte splashes into your eyes:
 - ▶ Wash your eyes repeatedly with cool water for at least 15 minutes. Using water under pressure can damage your eyes.
- Electrolyte splashes onto your skin:
 - ▶ Remove affected clothing and wash your skin thoroughly using water.
- Electrolyte splashes into your mouth:
 - ▶ Rinse mouth thoroughly with water, and do not swallow.

Maintenance Fundamentals

⚠WARNING

The battery gives off explosive hydrogen gas during normal operation.

A spark or flame can cause the battery to explode with enough force to kill or seriously hurt you.

Wear protective clothing and a face shield, or have a skilled mechanic do the battery servicing.

| Cleaning the Battery Terminals

1. Remove the battery.  P. 67
2. If the terminals are starting to corrode and are coated with a white substance, wash with warm water and wipe clean.

3. If the terminals are heavily corroded, clean and polish the terminals with a wire brush or sandpaper. Wear safety glasses.

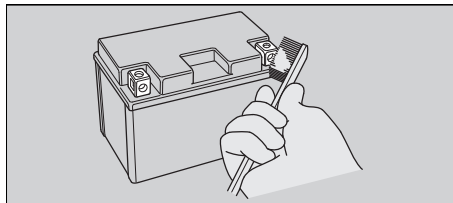

4. After cleaning, reinstall the battery.

The battery has a limited life span. Consult your dealer about when you should replace the battery. Always replace the battery with another maintenance-free battery of the same type.

NOTICE

Installing non-Honda electrical accessories can overload the electrical system, discharging the battery and possibly damaging the system.

Maintenance Fundamentals

Fuses

Fuses protect the electrical circuits on your motorcycle. If something electrical on your motorcycle stops working, check for and replace any blown fuses. 📖 P. 115

Inspecting and Replacing Fuses

Turn the ignition switch to the  (Off) position to remove and inspect fuses. If a fuse is blown, replace with a fuse of the same rating. For fuse ratings, see "Specifications." 📖 P. 131

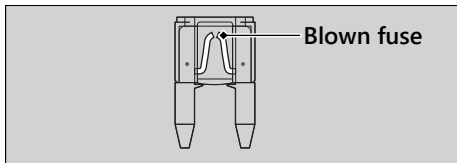

NOTICE

Replacing a fuse with one that has a higher rating greatly increases the chance of damage to the electrical system.

If a fuse fails repeatedly, you likely have an electrical fault. Have your motorcycle inspected by your dealer.

Engine Oil

Engine oil consumption varies and oil quality deteriorates according to riding conditions and time elapsed.

Check the engine oil level regularly, and add the recommended engine oil if necessary. Dirty oil or old oil should be changed as soon as possible.

Selecting the Engine Oil

For recommended engine oil, see "Specifications." 📖 P. 130

If you use non-Honda engine oil, check the label to make sure that the oil satisfies all of the following standards:

- JASO T 903 standard^{*1}: MA
- SAE standard^{*2}: 10W-30
- API classification^{*3}: SG or higher

Maintenance Fundamentals

- *1. The JASO T 903 standard is an index for engine oils for 4-stroke motorcycle engines. There are two classes: MA and MB. For example, the following label shows the MA classification.

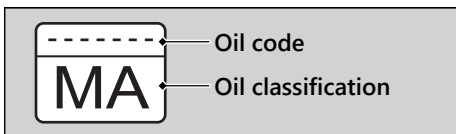

- *2. The SAE standard grades oils by their viscosity.
 *3. The API classification specifies the quality and performance rating of engine oils. Use SG or higher oils, excluding oils marked as "Energy Conserving" or "Resource Conserving" on the circular API service symbol.

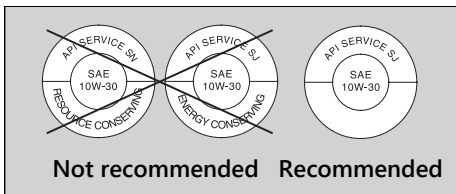

Brake Fluid

Do not add or replace brake fluid, except in an emergency. Use only fresh brake fluid from a sealed container. If you do add fluid, have the brake system serviced by your dealer as soon as possible.

NOTICE

Brake fluid can damage plastic and painted surfaces. Wipe up spills immediately and wash thoroughly.

Recommended brake fluid:

Honda DOT 3 or DOT 4 Brake Fluid or equivalent

Maintenance Fundamentals

Drive Chain

The drive chain must be inspected and lubricated regularly. Inspect the chain more frequently if you often ride on bad roads, ride at high speed, or ride with repeated fast acceleration. 📄 P. 88

If the chain does not move smoothly, makes strange noises, has damaged rollers, has loose pins, has missing O-rings, or kinks, have the chain inspected by your dealer.

Also inspect the drive sprocket and driven sprocket. If either has worn or damaged teeth, have the sprocket replaced by your dealer.

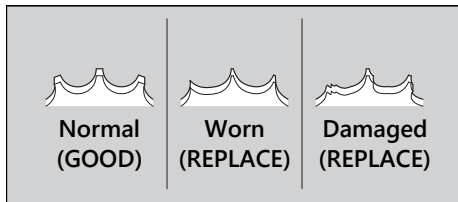

NOTICE

Use of a new chain with worn sprockets will cause rapid chain wear.

Cleaning and Lubricating

After inspecting the slack, clean the chain and sprockets while rotating the rear wheel. Use a dry cloth with chain cleaner designed specifically for O-ring chains, or neutral detergent. Use a soft brush if the chain is dirty. After cleaning, wipe dry and lubricate with the recommended lubricant.

Recommended lubricant:

Drive chain lubricant designed specifically for O-ring chains
If not available, use SAE 80 or 90 gear oil.

Maintenance Fundamentals

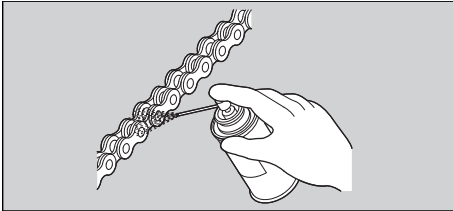

Do not use a steam cleaner, a high pressure cleaner, a wire brush, volatile solvent such as petrol and benzene, abrasive cleaner, chain cleaner or lubricant NOT designed specifically for O-ring chains as these can damage the rubber O-ring seals.
Avoid getting lubricant on the brakes or tyres.
Avoid applying excess chain lubricant to prevent spray onto your clothes and the motorcycle.

Recommended Coolant

Pro Honda HP Coolant is a pre-mixed solution of antifreeze and distilled water.

Concentration:

50% antifreeze and 50% distilled water

A concentration of antifreeze below 40% will not provide proper corrosion and cold temperature protection.
A concentration of up to 60% will provide better protection in colder climates.

NOTICE

Using coolant not specified for aluminium engines or tap/mineral water can cause corrosion.

Maintenance Fundamentals

Crankcase Breather

Service more frequently when riding in rain, at full throttle, or after the motorcycle is washed or overturned. Service if the deposit level can be seen in the transparent section of the drain tube.

If the drain tube overflows, the air filter may become contaminated with engine oil causing poor engine performance. ❏ P. 96

Tyres (Inspecting/Replacing)

Checking the Air Pressure

Visually inspect your tyres and use an air pressure gauge to measure the air pressure at least once a month or any time you think the tyres look low. Always check air pressure when your tyres are cold.

Inspecting for Damage

Inspect the tyres for cuts, slits, or cracks that exposes fabric or cords, or nails or other foreign objects embedded in the side of the tyre or the tread.

Also inspect for any unusual bumps or bulges in the side walls of the tyres.

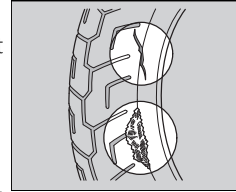

Inspecting for Abnormal Wear

Inspect the tyres for signs of abnormal wear on the contact surface.

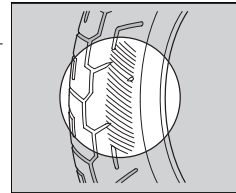

Inspecting Tread Depth

Inspect the tread wear indicators. If they become visible, replace the tyres immediately. For safe riding, you should replace the tyres when the minimum tread depth is reached.

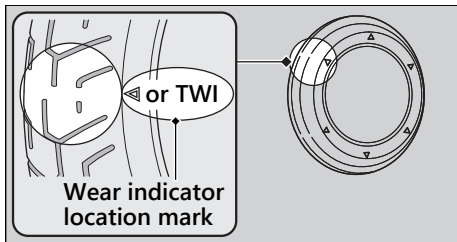

⚠ WARNING

Riding on tyres that are excessively worn or improperly inflated can cause a crash in which you can be seriously hurt or killed.

Follow all instructions in this owner's manual regarding tyre inflation and maintenance.

Germany

German law prohibits use of tyres whose tread depth is less than 1.6 mm.

Maintenance Fundamentals

Have your tyres replaced by your dealer. For recommended tyres, air pressure and minimum tread depth, see "Specifications."

➤ P. 130

Follow these guidelines whenever you replace tyres.

- Use the recommended tyres or equivalents of the same size, construction, speed rating, and load range.
- Have the wheel balanced with Honda Genuine balance weights or equivalent after the tyre is installed.
- Do not install a tube inside a tubeless tyre on this motorcycle. Excessive heat build-up can cause the tube to burst.
- Use only tubeless tyres on this motorcycle. The rims are designed for tubeless tyres, and during hard acceleration or braking, a tube-type tyre could slip on the rim and cause the tyre to rapidly deflate.

WARNING

Installing improper tyres on your motorcycle can adversely affect handling and stability, and can cause a crash in which you can be seriously hurt or killed.

Always use the size and type of tyres recommended in this owner's manual.

Air Cleaner

This motorcycle is equipped with a viscous type air cleaner element.

Air blow cleaning or any other cleaning can degrade the viscous element performance and cause the intake of dust.

Do not perform the maintenance. Should be serviced by your dealer.

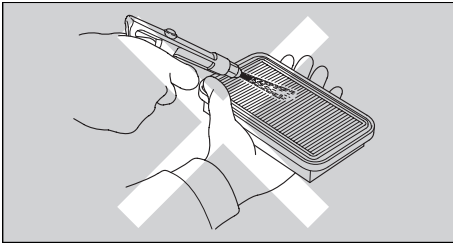

Tool

The tool kit is stored underside of the rear seat.

📄 P. 75

You can perform some roadside repairs, minor adjustments and parts replacement with the provided tools.

- 10 x 14 mm Open end wrench
- No.2 Phillips screwdriver
- Pin spanner
- Extension bar

Maintenance

Removing & Installing Body Components

Battery

Removal

Make sure the ignition switch is in the **O** (Off) position.

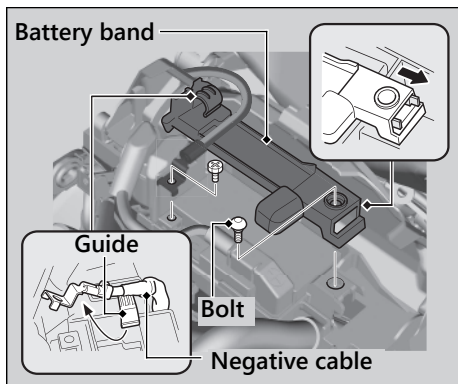

1. Raise the front of the fuel tank. **▶** P. 73
2. Disconnect the negative \ominus terminal from the battery.
3. Remove the negative \ominus cable from the guide.
4. Remove the bolt.
5. Slide the battery band and remove it.

Removing & Installing Body Components ► Battery

Maintenance

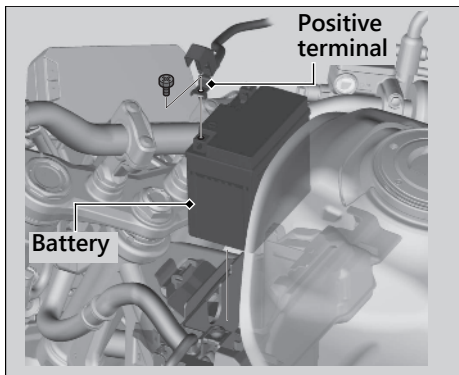

6. Disconnect the positive ⊕ terminal from the battery.
7. Remove the battery taking care not to drop the terminal nuts.
 - Cover the handlebar holders with a protective cloth to prevent the battery terminals from scratching them.

Installation

Install the parts in the reverse order of removal. Always connect the positive ⊕ terminal first. Make sure that bolts and nuts are tight.

Make sure the clock information is correct after the battery is reconnected. 📄 P. 28
For proper handling of the battery, see "Maintenance Fundamentals." 📄 P. 56
"Battery Goes Dead." 📄 P. 112

Removing & Installing Body Components ► Clip

Clip

Removal

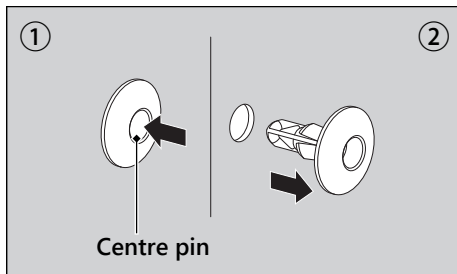

1. Press down on the centre pin to release the lock.
2. Pull the clip out of the hole.

Installation

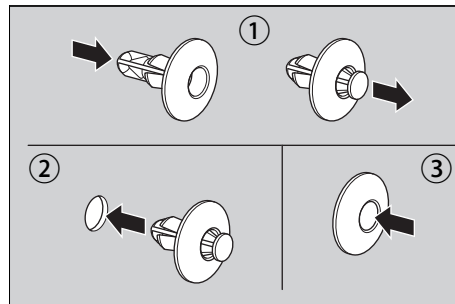

1. Push the bottom of the centre pin.
2. Insert the clip into the hole.
3. Press down on the centre pin to lock the clip.

Removing & Installing Body Components ► Front Seat

Front Seat

Removal

1. Remove the rear seat. ► P. 75
2. Remove the mounting bolts and collars, and then pull the front seat back and up.

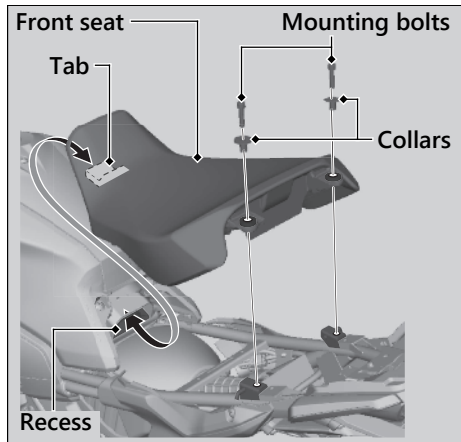

Installation

1. Insert the tab into the recess.
2. Install the collars and mounting bolts.
3. Tighten the mounting bolts securely.

Torque: 10 N·m (1.0 kgf·m, 7 lbf·ft)

- Make sure that the seat is locked securely in position by pulling it up lightly.
4. Install the rear seat. ► P. 75

Removing & Installing Body Components ► Fuel Tank Cover Assembly

Fuel Tank Cover Assembly

Removal

1. Remove the front seat. ► P. 70
2. Remove the bolts A.

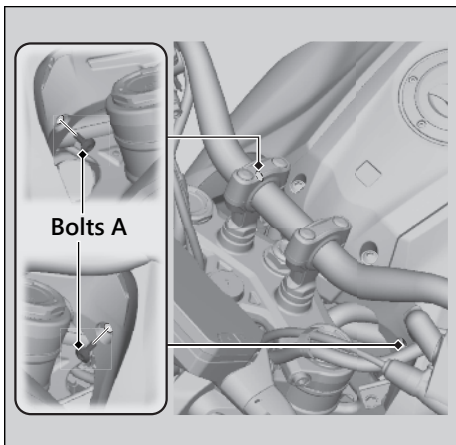

3. Remove the bolts B, bolts C, collars, bolt D and washer.

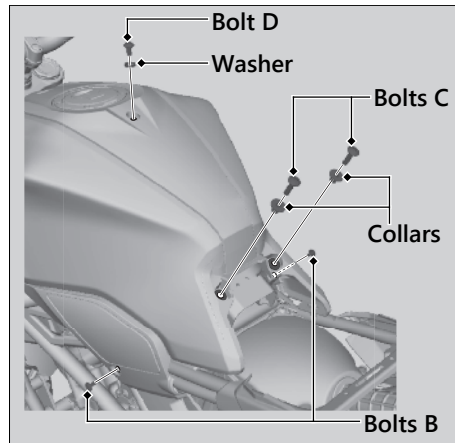

Removing & Installing Body Components ► Fuel Tank Cover Assembly

4. Remove the prongs from the grommets and release the slots from the tabs.
5. Carefully widen the both ends of the fuel tank cover assembly and remove it.
 - Be careful not to apply weight to the fuel tank cover assembly.

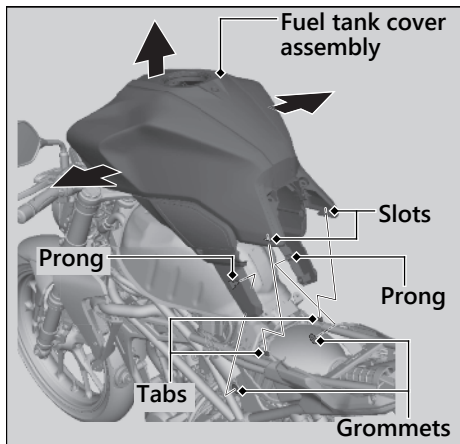

Installation

1. Install the fuel tank cover assembly in the reverse order of removal.
2. Tighten the bolts C and bolt D securely.

Torque: 10 N·m (1.0 kgf·m, 7 lbf·ft)

3. Tighten the bolts A and bolts B securely.

Torque: 4.2 N·m (0.4 kgf·m, 3.1 lbf·ft)

4. Install the front and rear seat. ► P. 70

Removing & Installing Body Components ► Fuel Tank Maintenance Position

Fuel Tank Maintenance Position

The front of the fuel tank can be tilted up for maintenance.

The fuel tank does not require draining.

Raising The Fuel Tank

1. Place the motorcycle on its side stand on a firm, level surface with the transmission in neutral and turn the ignition switch to the **O** (Off) position.
Check that the fuel fill cap is closed.
2. Settle the handlebar straight ahead.
3. Remove the fuel tank cover assembly.
► P. 71

4. Remove the mounting bolts and collars on both sides.

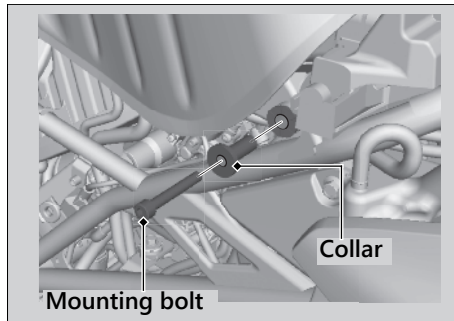

5. Raise the front of the fuel tank.

Removing & Installing Body Components ► Fuel Tank Maintenance Position

6. Pull the tab of the battery cover and open it.
 - After the battery cover is opened, push down the hinge part to lock it.

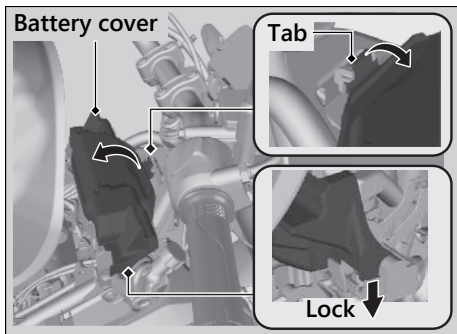

7. Mount the fuel tank on the base of the battery cover.

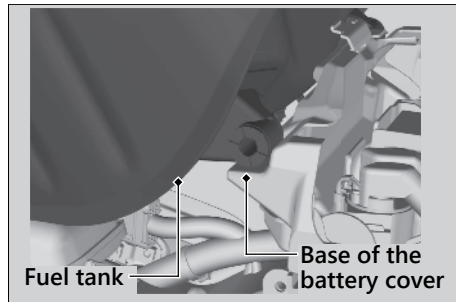

Installation

1. Install the fuel tank in the reverse order of removal.
2. Install the collars and mounting bolts.
3. Tighten the mounting bolts.

Torque: 12 N·m (1.2 kgf·m, 9 lbf·ft)

Removing & Installing Body Components ► Rear Seat

Rear Seat

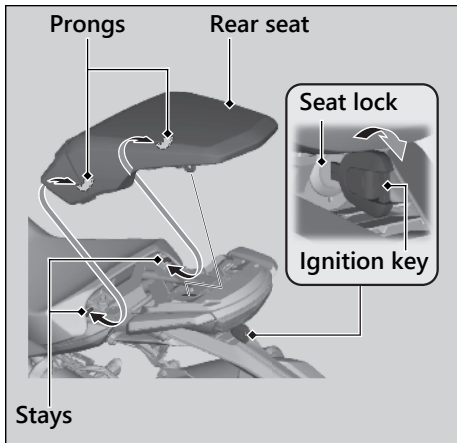

Removal

1. Insert the ignition key into the seat lock.
2. Turn it clockwise, then pull the rear seat up and back.

Installation

1. Insert the prongs into the stays on the frame.
2. Push and down on the rear of the rear seat until it locks in place.
 - Make sure that the seat is locked securely in position by pulling it up lightly.

The seat locks automatically when closed. Take care not to lock your key in the compartment under the rear seat.

Removing & Installing Body Components ► Shroud

Shroud

The right and left shrouds can be removed in the same manner.

Removal

1. Remove the clip (► P. 69) and outer shroud bolt.
2. Remove the outer shroud by releasing the tab from the slot on the inner shroud.

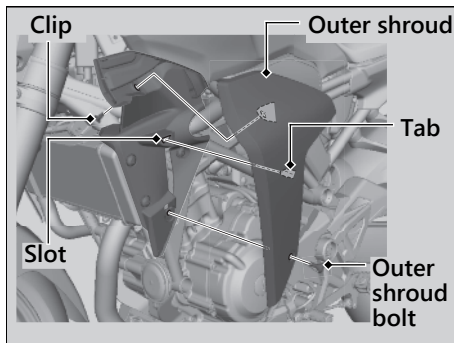

Removing & Installing Body Components ► Shroud

3. Remove the inner shroud bolt A, bolts B and inner shroud.

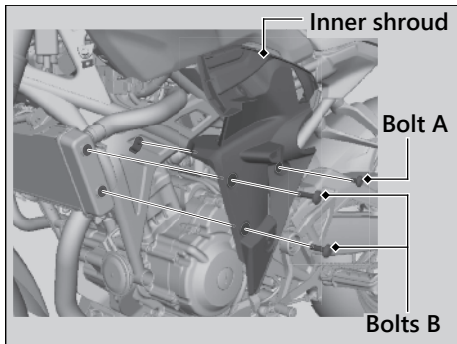

Installation

1. Install the inner shroud and tighten the inner shroud bolts B.

Torque: 10 N·m (1.0 kgf·m, 7 lbf·ft)

2. Install and tighten the inner shroud bolt A.

Torque: 4.2 N·m (0.4 kgf·m, 3.1 lbf·ft)

3. Install the outer shroud by inserting its tab into the slot on the inner shroud.

4. Install and tighten the outer shroud bolt.

Torque: 4.2 N·m (0.4 kgf·m, 3.1 lbf·ft)

5. Install the clip.

Engine Oil

Checking the Engine Oil

1. If the engine is cold, idle the engine for 3 to 5 minutes.
2. Turn the ignition switch to the **O** (Off) position and wait for 2 to 3 minutes.
3. Place your motorcycle in an upright position on a firm, level surface.
4. Check that the oil level is between the upper level and lower level marks on the oil level inspection window.

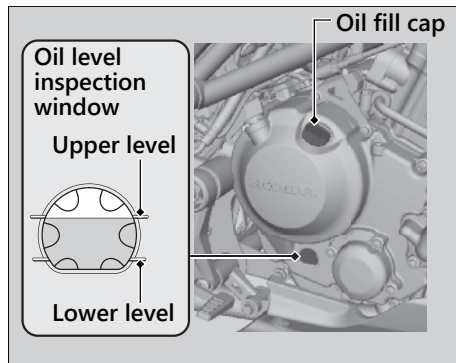

Adding Engine Oil

If the engine oil is below or near the lower level mark, add the recommended engine oil.

► P. 58, ► P. 130

1. Remove the oil fill cap. Add the recommended oil until it reaches the upper level mark.
 - Place your motorcycle in an upright position on a firm, level surface when checking the oil level.
 - Do not overfill above the upper level mark.
 - Make sure no foreign objects enter the oil filler opening.
 - Wipe up any spills immediately.
2. Securely reinstall the oil fill cap.

NOTICE

Overfilling with oil or operating with insufficient oil can cause damage to your engine. Do not mix different brands and grades of oil. They may affect lubrication and clutch operation.

For the recommended oil and oil selection guidelines, see “Maintenance Fundamentals.”

► P. 58

Engine Oil ► Changing Engine Oil & Filter

Changing Engine Oil & Filter

Changing the oil and filter requires special tools. We recommend that you have your motorcycle serviced by your dealer.

Use a new Honda Genuine oil filter or equivalent specified for your model.

NOTICE

Using the wrong oil filter can result in serious damage to the engine.

1. If the engine is cold, idle the engine for 3 to 5 minutes.
2. Turn the ignition switch to the **○** (Off) position and wait for 2 to 3 minutes.
3. Place your motorcycle on a firm, level surface.
4. Place a drain pan under the drain bolt.

5. Remove the oil fill cap, drain bolt, and sealing washer to drain the oil.

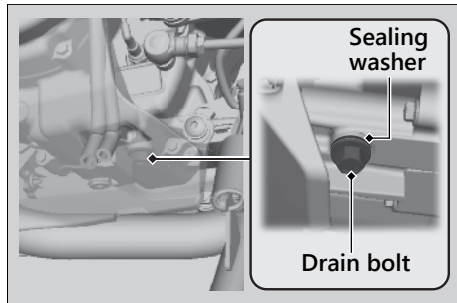

6. Remove the oil filter cover, oil filter, spring and gasket by removing the oil filter cover bolts and let the remaining oil drain out.
 - Discard the oil and oil filter at an approved recycling centre.

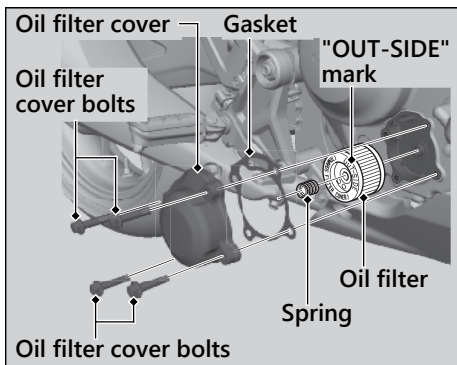

7. Install a new oil filter with its "OUT-SIDE" mark facing out.
8. Install the oil filter spring into the oil filter cover, and then install the oil filter cover with a new gasket.
9. Install and tighten the oil filter cover bolts.

Torque: 12 N·m (1.2 kgf·m, 9 lbf·ft)

Engine Oil ► Changing Engine Oil & Filter

10. Install a new sealing washer onto the drain bolt. Tighten the drain bolt.

Torque: 24 N·m (2.4 kgf·m, 18 lbf·ft)

11. Fill the crankcase with the recommended oil (➤ P. 58, ➤ P. 130) and install the oil fill cap.

Required oil

When changing oil & engine oil filter:

1.5 L (1.6 US qt, 1.3 Imp qt)

When changing oil only:

1.4 L (1.5 US qt, 1.2 Imp qt)

12. Check the oil level. ➤ P. 78
13. Check that there are no oil leaks.

NOTICE

Improper installation of the oil filter can result in serious damage to the engine.

Coolant

Checking the Coolant

Check the coolant level in the reserve tank while the engine is cold.

1. Place your motorcycle on a firm, level surface.
2. Hold your motorcycle in an upright position and turn the handlebar to the left.
3. Remove the reserve tank cap/dipstick and wipe it clean.
4. Insert the reserve tank cap/dipstick until it seats, but don't screw it in.
5. Check that the coolant level is between the upper level and lower level marks on the gauge.
6. Securely install the reserve tank cap/ dipstick.

If the coolant level is dropping noticeably or the reserve tank is empty, you likely have a serious leak. Have your motorcycle inspected by your dealer.

Reserve tank cap/dipstick

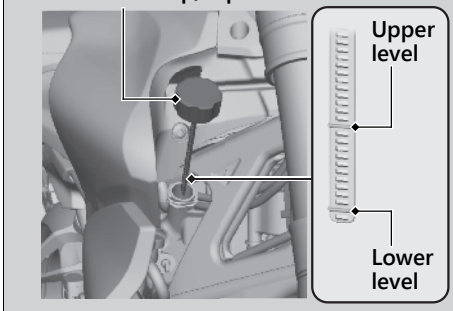

Adding Coolant

If the coolant level is below the lower level mark, add the recommended coolant (P. 61) until the level reaches the upper level mark.

Add fluid only from the reserve tank cap/ dipstick and do not remove the radiator cap.

Coolant ► Changing Coolant

1. Remove the reserve tank cap/dipstick and add fluid while monitoring the coolant level.
 - Do not overfill above the upper level mark.
 - Make sure no foreign objects enter the reserve tank opening.
2. Securely reinstall the reserve tank cap/dipstick.

⚠WARNING

Removing the radiator cap while the engine is hot can cause the coolant to spray out, potentially scalding you.

Always let the engine and radiator cool down before removing the radiator cap.

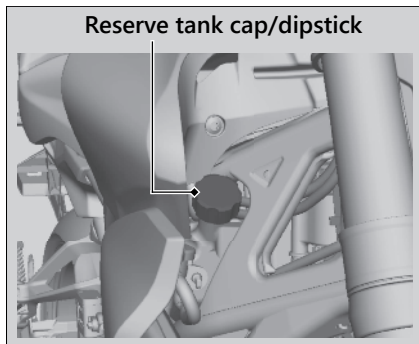

Changing Coolant

Have your dealer change the coolant unless you have the proper tools and are mechanically qualified.

Brakes

Checking Brake Fluid

1. Place your motorcycle in an upright position on a firm, level surface.
2. **Front** Check that the brake fluid reservoir is horizontal and that the fluid level is above the LWR mark.
Rear Check that the brake fluid reservoir is horizontal and that the fluid level is between the LOWER level and UPPER level marks.

If the brake fluid level in either reservoir is below the LWR mark or LOWER level mark or the brake lever and pedal freeplay becomes excessive, inspect the brake pads for wear. If the brake pads are not worn, you most likely have a leak. Have your motorcycle inspected by your dealer.

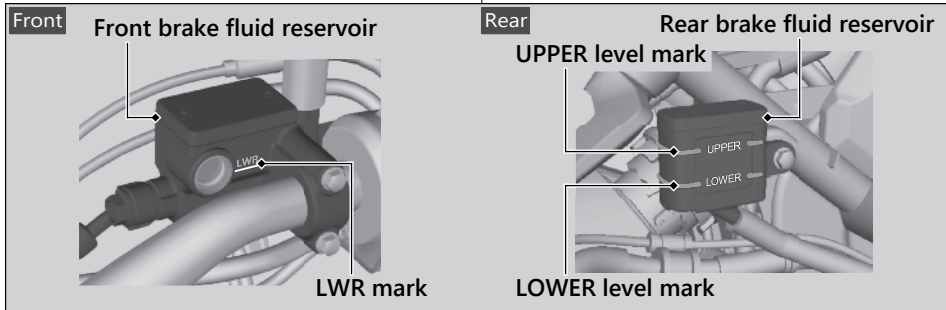

Inspecting the Brake Pads

Check the condition of the brake pad wear indicators.

Front The pads need to be replaced if a brake pad is worn to the bottom of the indicator.

Rear The pads need to be replaced if a brake pad is worn to the indicator.

1. **Front** Inspect the brake pads from in front of the brake caliper.
2. **Rear** Inspect the brake pads from the rear right of the motorcycle.

If necessary have the pads replaced by your dealer.

Always replace both left and right brake pads at the same time.

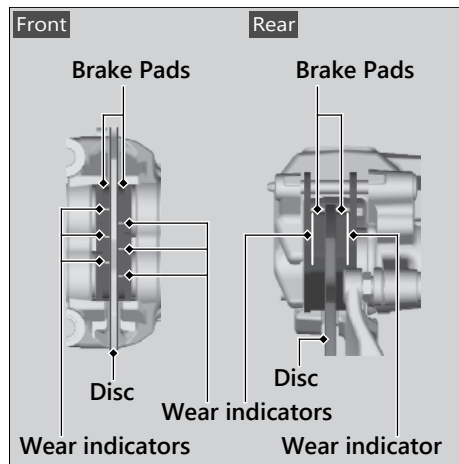

Brakes ► Adjusting the Brakelight Switch

Adjusting the Brakelight Switch

Check the operation of the brakelight switch. Hold the brakelight switch and turn the adjusting nut in the direction A if the switch operates too late, or turn the nut in the direction B if the switch operates too soon.

Maintenance

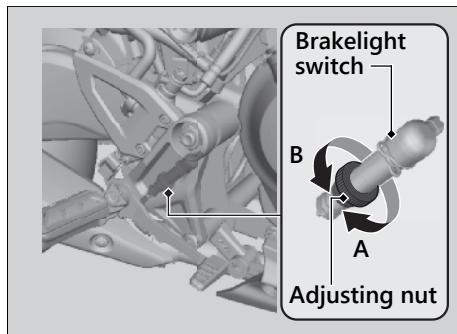

Side Stand

Checking the Side Stand

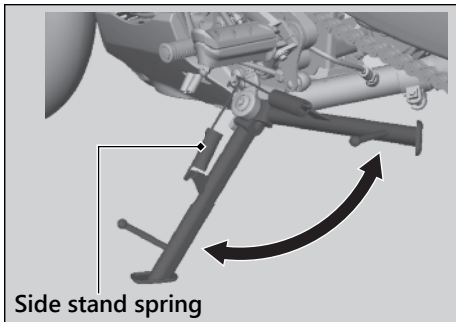

1. Check that the side stand operates smoothly. If the side stand is stiff or squeaky, clean the pivot area and lubricate the pivot bolt with clean grease.
2. Check the spring for damage or loss of tension.

3. Sit on the motorcycle, shift the transmission to Neutral, and raise the side stand.
4. Start the engine, pull the clutch lever in, and shift the transmission into gear.
5. Lower the side stand all the way. The engine should stop as you lower the side stand. If the engine doesn't stop, have your motorcycle inspected by your dealer.

Drive Chain

Inspecting the Drive Chain Slack

Maintenance

Check the drive chain slack at several points along the chain. If the slack is not constant at all points, some links may be kinked and binding.

Have the chain inspected by your dealer.

1. Shift the transmission to Neutral. Stop the engine.
2. Place your motorcycle on its side stand on a firm, level surface.
3. Check the slack in the lower half of the drive chain midway between the sprockets.

Drive chain slack:

30 - 40 mm (1.2 - 1.6 in)

- ▶ Do not ride your motorcycle if the slack exceeds 50 mm (2.0 in).

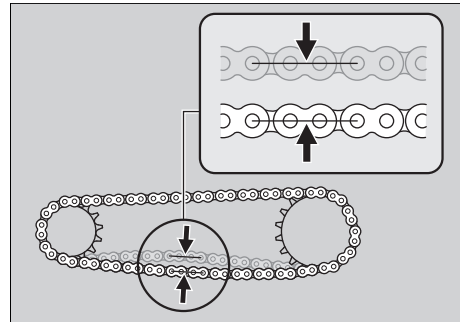

4. Roll the motorcycle forward and check that the chain moves smoothly.
5. Inspect the sprockets. ➤ P. 60
6. Clean and lubricate the drive chain. ➤ P. 60

Drive Chain ► Adjusting the Drive Chain Slack

Adjusting the Drive Chain Slack

Adjusting the chain requires special tools. Have the drive chain slack adjusted by your dealer.

When adjusting the drive chain slack, be careful not to damage the wheel speed sensor and pulser ring.

1. Shift the transmission to Neutral. Stop the engine.
2. Place your motorcycle on its side stand on a firm, level surface.
3. Loosen the rear axle nut.
4. Loosen the lock nuts on both sides of the swingarm.

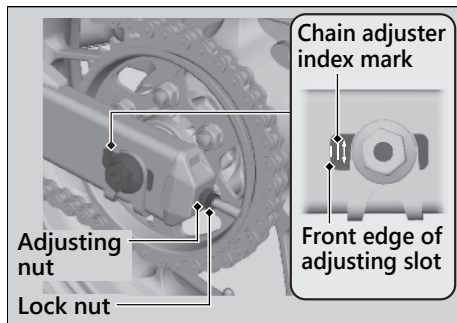
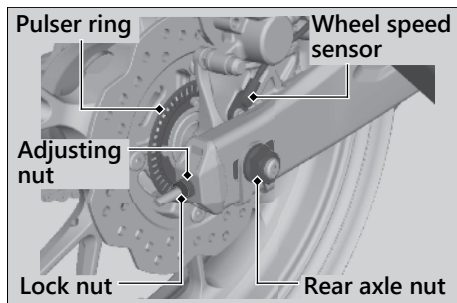

Drive Chain ► Adjusting the Drive Chain Slack

5. Turn both adjusting nuts an equal number of turns until the correct drive chain slack is obtained. Turn the adjusting nuts clockwise to tighten the chain. Turn the adjusting nuts counterclockwise and push the rear wheel toward the front to provide more slack.

Adjust the slack at a point midway between the drive sprocket and the driven sprocket.

Check the drive chain slack.  P. 88

6. Check rear axle alignment by making sure the chain adjuster index marks align with the front edge of the adjusting slots. Both marks should correspond. If the axle is misaligned, turn the right or left adjusting nuts until the marks are aligned and recheck drive chain slack.

7. Tighten the rear axle nut.

Torque: 88 N·m (9.0 kgf·m, 65 lbf·ft)

8. Tighten the drive chain adjusting nuts lightly, then hold the adjusting nuts and tighten the lock nuts.
9. Recheck drive chain slack.

If a torque wrench was not used for installation, see your dealer as soon as possible to verify proper assembly. Improper assembly may lead to loss of braking capacity.

Drive Chain ► Checking the Drive Chain Slider

Checking the Drive Chain Wear

Check the chain wear label when adjusting the drive chain. If the arrow mark on the drive chain adjuster enters the red zone on the label after the chain has been adjusted to the proper slack, the chain is excessively worn and must be replaced.

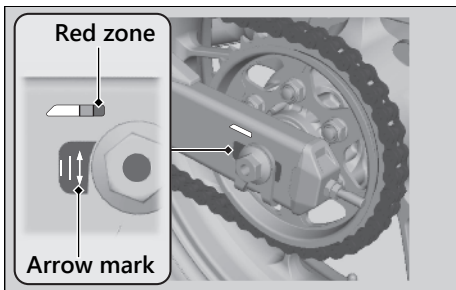
**Chain:**

DID 520VF or RK 520KLO2

If necessary have the drive chain replaced by your dealer.

Checking the Drive Chain Slider

Check the condition of the drive chain slider. The drive chain slider will need to be replaced if the chain slider is worn to the bottom of any wear indicator. If necessary have the drive chain slider replaced by your dealer.

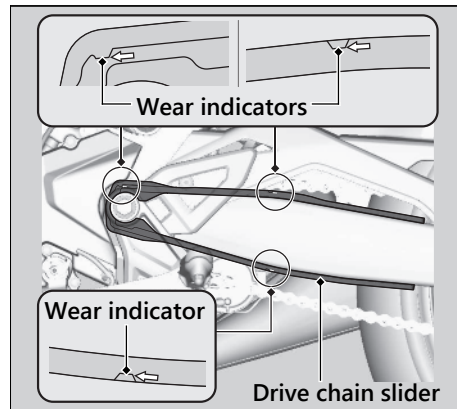

Clutch

Checking the Clutch

Checking the Clutch Lever Freeplay

Check the clutch lever freeplay.

Freeplay at the clutch lever:

10 - 20 mm (0.4 - 0.8 in)

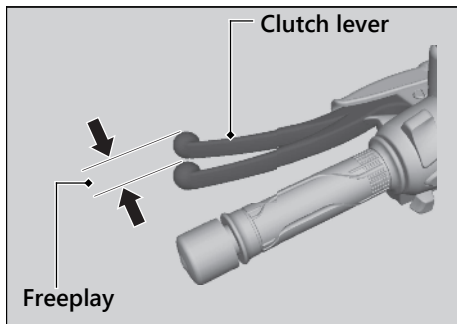

Check the clutch cable for kinks or signs of wear. If necessary have it replaced by your dealer.

Lubricate the clutch cable with a commercially available cable lubricant to prevent premature wear and corrosion.

NOTICE

Improper freeplay adjustment can cause premature clutch wear.

Clutch ► Adjusting the Clutch Lever Freeplay

Adjusting the Clutch Lever Freeplay

I Upper Adjustment

Attempt adjustment with the upper clutch cable adjuster first.

1. Pull back the rubber dust cover.
2. Loosen the upper lock nut.
3. Turn the upper clutch cable adjuster until the freeplay is 10 - 20 mm (0.4 - 0.8 in).
4. Tighten the upper lock nut and check the freeplay again.
5. Install the rubber dust cover.

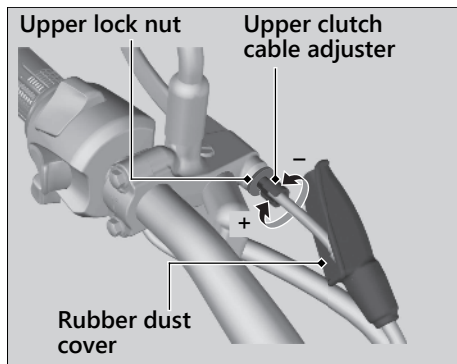

Maintenance

Clutch ► Adjusting the Clutch Lever Freeplay

Lower Adjustment

If the upper clutch cable adjuster is threaded out near its limit, or the correct freeplay cannot be obtained, attempt adjustment with the lower clutch cable adjusting nut.

1. Loosen the upper lock nut and turn the upper clutch cable adjuster all the way in (to provide maximum freeplay). Tighten the upper lock nut.
2. Loosen the lower lock nut.
3. Turn the lower adjusting nut until the clutch lever freeplay is 10 - 20 mm (0.4 - 0.8 in).
4. Tighten the lower lock nut and check the clutch lever freeplay.
5. Start the engine, pull the clutch lever in, and shift into gear. Make sure the engine does not stall and the motorcycle does not creep. Gradually release the clutch lever and open the throttle. Your motorcycle should move smoothly and accelerate gradually.

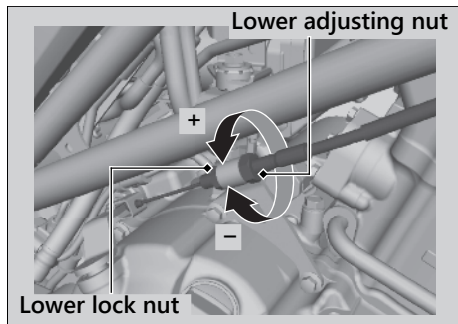

If proper adjustment cannot be obtained or the clutch does not work correctly, see your dealer.

Throttle

Checking the Throttle

With the engine off, check that the throttle rotates smoothly from fully closed to fully open in all steering positions and throttle freeplay is correct. If the throttle does not move smoothly, close automatically, or if the cable is damaged, have the motorcycle inspected by your dealer.

Freeplay at the throttle grip flange:

2 - 6 mm (0.1 - 0.2 in)

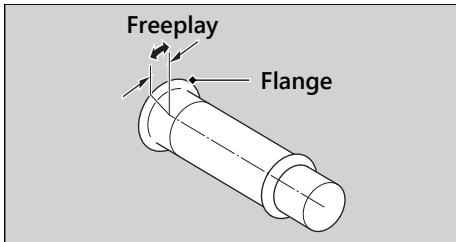

Crankcase Breather

Cleaning the Crankcase Breather

Maintenance

1. Place a suitable container under the crankcase breather tube.
2. Remove the crankcase breather tube plug from the tube.
3. Drain deposits into a suitable container.
4. Install the crankcase breather tube plug.

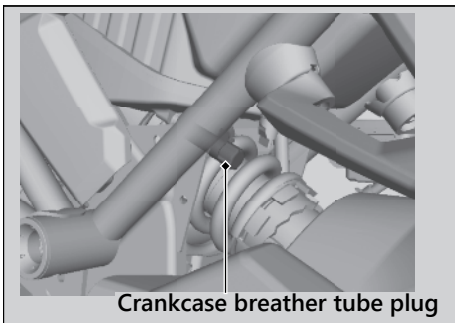

Other Adjustments

Adjusting the Headlight Aim

You can adjust vertical aim of the headlight for proper alignment. Turn the pinion in or out as necessary using provided Phillips screwdriver (▶ P. 66).

Obey local laws and regulations.

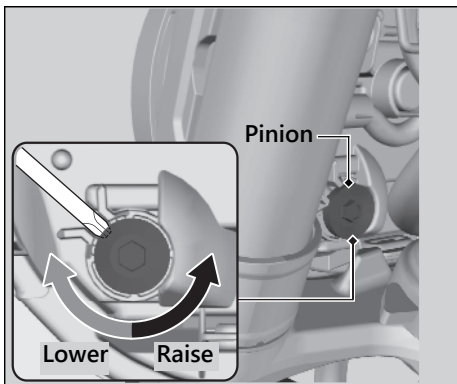

Other Adjustments ► Adjusting the Rear Suspension

Adjusting the Rear Suspension

I Spring Preload

You can adjust the spring preload by the adjuster to suit the load or the road surface. Turn the adjuster using the pin spanner and extension bar provided in the tool kit (▶ P. 66).

Position 1 is for a decrease spring preload (soft), or turn the position 3 to 7 increase spring preload (hard). The standard position is 2.

Maintenance

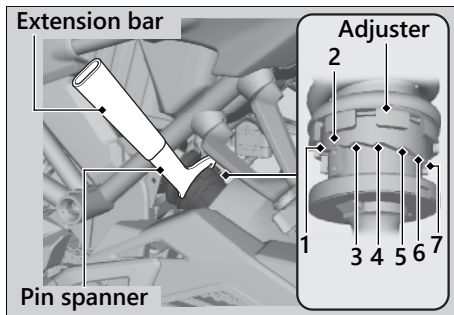

NOTICE

Attempting to adjust directly from 1 to 7 or 7 to 1 may damage the shock absorber.

NOTICE

Do not turn the adjuster beyond its limits.

NOTICE

The rear shock absorber damper unit contains high pressure nitrogen gas. Do not attempt to disassemble, service, or improperly dispose of the damper. See your dealer.

Troubleshooting

Engine Will Not Start	P. 100	Unstable Engine Operation Occurs Intermittently	P. 116
Overheating (Segment H flashes in coolant temperature gauge)	P. 101		
Warning Indicators On or Flashing	P. 102		
PGM-FI (Programmed Fuel Injection)			
Malfunction Indicator Lamp (MIL).....	P. 102		
ABS (Anti-lock Brake System) Indicator	P. 103		
Other Warning Indications	P. 104		
Fuel Gauge Failure Indication.....	P. 104		
Tyre Puncture	P. 105		
Electrical Trouble	P. 112		
Battery Goes Dead.....	P. 112		
Burned-out Light Bulb	P. 112		
Blown Fuse.....	P. 115		

Engine Will Not Start

Starter Motor Operates But Engine Does Not Start

Check the following items:

- Check the correct engine starting sequence. ➤ P. 43
- Check that there is petrol in the fuel tank.
- Check if the PGM-FI malfunction indicator lamp (MIL) is on.
 - ▶ If the indicator lamp is on, contact your dealer as soon as possible.

Troubleshooting

Starter Motor Does Not Operate

Check the following items:

- Check the correct engine starting sequence. ➤ P. 43
- Make sure engine stop switch is in the  (Run) position. ➤ P. 40
- Check for a blown fuse. ➤ P. 115
- Check for a loose battery connection (➤ P. 67) or battery terminal corrosion (➤ P. 56).
- Check the condition of the battery.
 - P. 112

If the problem continues, have your motorcycle inspected by your dealer.

Overheating (Segment H flashes in coolant temperature gauge)

The engine is overheating when the following occurs:

- The segment H flashes in the coolant temperature gauge.
- Acceleration becomes sluggish.
If this occurs, pull safely to the side of the road and perform the following procedure.

Extended fast idling may cause the segment H to flash.

NOTICE

Continuing to ride with an overheated engine can cause serious damage to the engine.

1. Stop the engine using the ignition switch, and then turn the ignition switch to the **I** (On) position.

2. Check that the radiator fan is operating, and then turn the ignition switch to the **O** (Off) position.
If the fan is not operating:
Suspect a fault. Do not start the engine. Transport your motorcycle to your dealer.

If the fan is operating:

Allow the engine to cool with the ignition switch in the **O** (Off) position.

3. After the engine has cooled, inspect the radiator hose and check if there is a leak.
➔ P. 82

If there is a leak:

Do not start the engine. Transport your motorcycle to your dealer.

4. Check the coolant level in the reserve tank. ➔ P. 82
▶ Add coolant as necessary.
5. If 1-4 check normal, you may continue riding, but closely monitor the temperature gauge.

Warning Indicators On or Flashing

PGM-FI (Programmed Fuel Injection) Malfunction Indicator Lamp (MIL)

If the indicator comes on while riding, you may have a serious problem with the PGM-FI system. Reduce speed and have your motorcycle inspected by your dealer as soon as possible.

Troubleshooting

Warning Indicators On or Flashing ► ABS (Anti-lock Brake System) Indicator

ABS (Anti-lock Brake System) Indicator

If the indicator operates in one of the following ways, you may have a serious problem with the ABS. Reduce your speed and have your motorcycle inspected by your dealer as soon as possible.

- Indicator comes on or starts flashing while riding.
- Indicator does not come on when the ignition switch is in the **I** (On) position.
- Indicator does not go off at speeds above 10 km/h (6 mph).

If the ABS indicator stays on, your brakes will continue to work as a conventional system, but without the anti-locking function.

The ABS indicator may flash if you turn the rear wheel while your motorcycle is lifted off the ground. In this case, turn the ignition switch to the **O** (Off) position, and then to the **I** (On) position again. The ABS indicator will go off after your speed reaches 30 km/h (19 mph).

Other Warning Indications

Fuel Gauge Failure Indication

If the fuel system has an error, the fuel gauge indicators will be displayed as shown in the illustration.

If this occurs, see your dealer as soon as possible.

Troubleshooting

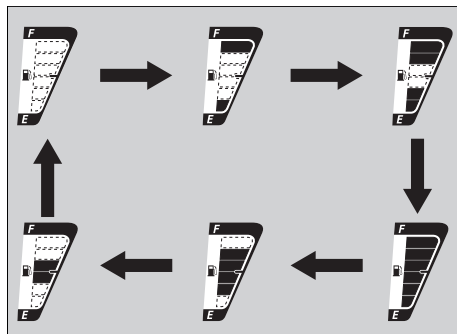
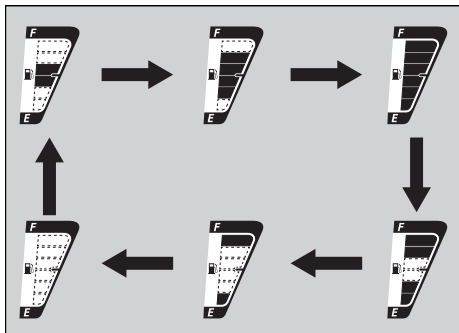

Tyre Puncture

Repairing a puncture or removing a wheel requires special tools and technical expertise. We recommend you have this type of service performed by your dealer. After an emergency repair, always have the tyre inspected/replaced by your dealer.

Emergency Repair Using a Tyre Repair Kit

If your tyre has a minor puncture, you can make an emergency repair using a tubeless tyre repair kit.

Follow the instructions provided with the emergency tyre repair kit.

Riding your motorcycle with a temporary tyre repair is very risky. Do not exceed 50 km/h (30 mph). Have the tyre replaced by your dealer as soon as possible.

⚠ WARNING

Riding your motorcycle with a temporary tyre repair can be risky. If the temporary repair fails, you can crash and be seriously injured or killed.

If you must ride with a temporary tyre repair, ride slowly and carefully and do not exceed 50 km/h (30 mph) until the tyre is replaced.

Removing Wheels

Follow these procedures if you need to remove a wheel in order to repair a puncture.

Tyre Puncture ► Removing Wheels

When removing and installing the wheel, be careful not to damage the wheel speed sensor and pulser ring.

Front Wheel

Removal

1. Place your motorcycle on a firm, level surface.
2. Cover right side of the front wheel and brake caliper with protective tape or cloth.
3. Loosen the front axle nut.
4. Loosen the axle pinch bolt on both sides.
5. Support your motorcycle securely and raise the front wheel off the ground using a maintenance stand or a hoist.

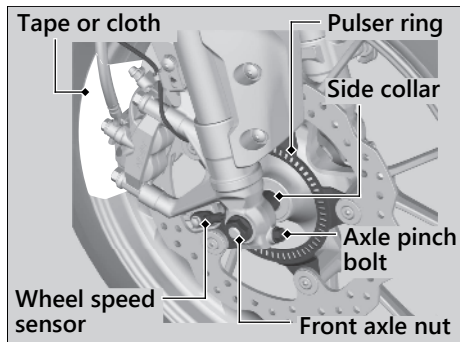

Tyre Puncture ► Removing Wheels

6. Remove the front axle nut, front axle shaft, front wheel and side collars.
 - Avoid getting grease, oil, or dirt on the disc or pad surfaces.
 - Do not pull the brake lever while the front wheel is removed.

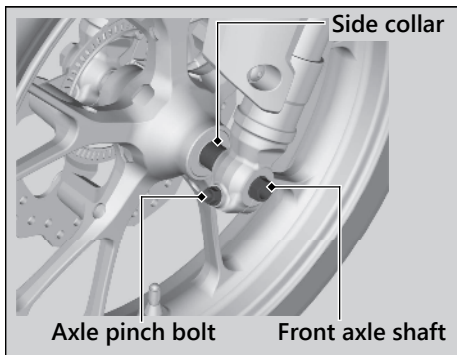
**Installation**

1. Attach the side collars to the front wheel.
2. Position the front wheel between the fork legs and insert the front axle shaft from the left side, through the left fork leg and wheel hub.

NOTICE

When installing a wheel or caliper into original position, carefully fit the brake disc between the pads to avoid scratching them.

3. Install and tighten the front axle nut.

Torque: 59 N·m (6.0 kgf·m, 44 lbf·ft)

4. Tighten the axle pinch bolt on both sides.

Torque: 24 N·m (2.4 kgf·m, 18 lbf·ft)

Tyre Puncture ► Removing Wheels

5. After installing the wheel, apply the brake lever several times, then check if the wheel rotates freely. Recheck the wheel if the brake drags or if the wheel does not rotate freely.
6. Remove the protective tape or cloth.

Troubleshooting

If a torque wrench was not used for installation, see your dealer as soon as possible to verify proper assembly. Improper assembly may lead to loss of braking capacity.

Tyre Puncture ► Removing Wheels

Rear Wheel**Removal**

1. Support your motorcycle securely and raise the rear wheel off the ground using a maintenance stand or a hoist.
2. Loosen the rear axle nut, lock nuts and turn the adjusting nuts so the rear wheel can be moved all the way forward for maximum drive chain slack.
3. Remove the rear axle nut and axle washer.

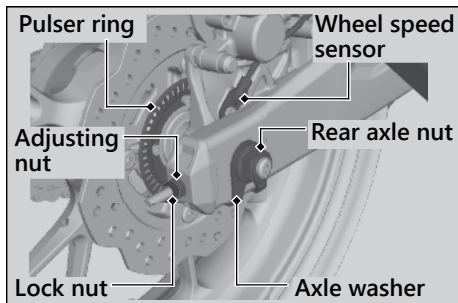

4. Remove the drive chain from the driven sprocket by pushing the rear wheel forward.

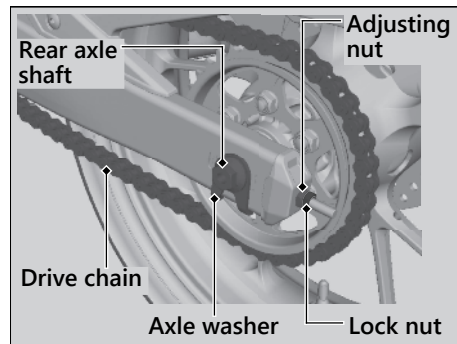

Troubleshooting

Tyre Puncture ► Removing Wheels

5. Remove the rear axle shaft, side collars, axle washer and rear wheel.
 - Support the brake caliper assembly so that it doesn't hang from the brake hose. Do not twist the brake hose.
 - Avoid getting grease, oil, or dirt on the disc or pad surfaces.
 - Do not push the brake pedal while the brake caliper is removed.

Troubleshooting

Installation

1. Attach the right and left side collars in their original locations on the wheel.
2. To install the rear wheel, reverse the removal procedure.
 - Take care to prevent the brake caliper from scratching the wheel during installation.

NOTICE

When installing a wheel or caliper into original position, carefully fit the brake disc between the pads to avoid scratching them.

Tyre Puncture ► Removing Wheels

3. Make sure that the lug on the brake caliper bracket is positioned in the slot on the swingarm.

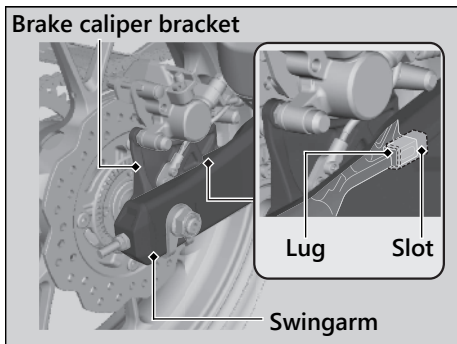

4. Adjust the drive chain slack. ► P. 89
5. Install and tighten the rear axle nut.

Torque: 88 N·m (9.0 kgf·m, 65 lbf·ft)

6. Tighten the drive chain adjusting nuts lightly, then hold the adjusting nuts and tighten the lock nuts.
7. After installing the wheel, apply the brake pedal several times, then check if the wheel rotates freely. Recheck the wheel if the brake drags or if the wheel does not rotate freely.

If a torque wrench was not used for installation, see your dealer as soon as possible to verify proper assembly. Improper assembly may lead to loss of braking capacity.

Electrical Trouble

Battery Goes Dead

Charge the battery using a motorcycle battery charger.

Remove the battery from the motorcycle before charging.

Do not use an automobile-type battery charger, as these can overheat a motorcycle battery and cause permanent damage. If the battery does not recover after recharging, contact your dealer.

NOTICE

Jump starting using an automobile battery can damage your motorcycle's electrical system and is not recommended.

Burned-out Light Bulb

All light bulbs on the motorcycle are LEDs. If there is a LED which is not turned on, see your dealer for servicing.

Electrical Trouble ► Burned-out Light Bulb

| Headlight

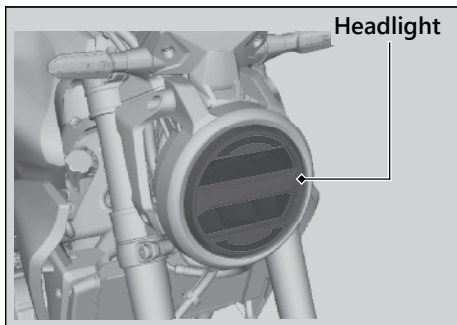

The headlight uses several LEDs.
If there is a LED which is not turned on, see
your dealer for servicing.

| Brakelight/Taillight

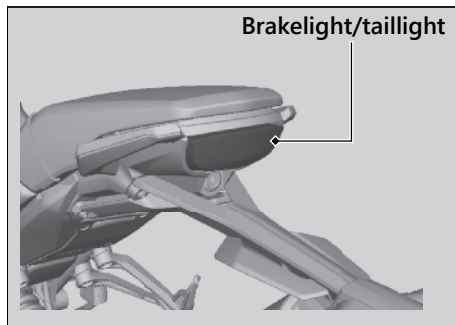

The brakelight and taillight use several LEDs.
If there is a LED which is not turned on, see
your dealer for servicing.

Electrical Trouble ► Burned-out Light Bulb

Front and Rear Turn Signal Lights

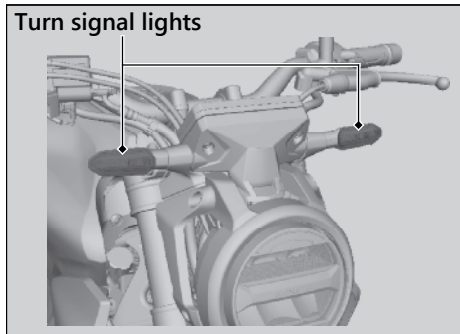

The front and rear turn signal lights use several LEDs. If there is a LED which is not turned on, see your dealer for servicing.

License Plate Light

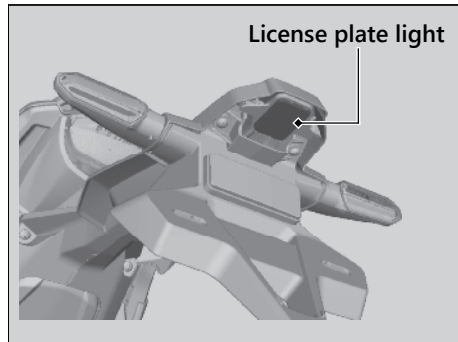

The license plate light uses a LED. If there is a LED which is not turned on, see your dealer for servicing.

Blown Fuse

Before handling fuses, see “Inspecting and Replacing Fuses.” ▣ P. 58

Fuse Box Fuses

1. Remove the left shroud. ▣ P. 76
2. Pull out the fuse boxes from the battery case.
3. Open the fuse box covers.
4. Pull out the fuses one by one with the fuse puller and check for a blown fuse.
Always replace a blown fuse with a spare fuse of the same rating.
5. Close the fuse box covers.
6. Reinstall parts in the reverse order of removal.

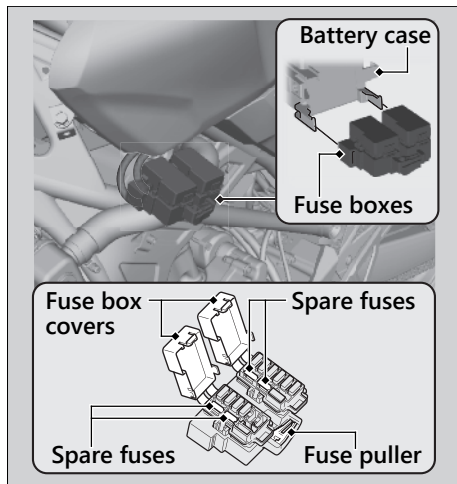

NOTICE

If a fuse fails repeatedly, you likely have an electrical problem. Have your motorcycle inspected by your dealer.

Unstable Engine Operation Occurs Intermittently

If the fuel pump filter is clogged, unstable engine operation will occur intermittently while riding.

Even if this symptom occurs, you can continue to ride your motorcycle.

If unstable engine operation occurs even if sufficient fuel is available, have your motorcycle inspected by your dealer as soon as possible.

Troubleshooting

Information

Keys.....	P. 118
Instruments, Controls, & Other Features...	P. 119
Caring for Your Motorcycle	P. 120
Storing Your Motorcycle	P. 123
Transporting Your Motorcycle.....	P. 124
You & the Environment	P. 125
Serial Numbers	P. 126
Fuels Containing Alcohol	P. 127
Catalytic Converter	P. 128

Keys

Keys

Ignition Key

This motorcycle has two ignition keys and a key tag with a key number and a bar code. Store the spare key and the key tag in a safe location. To make a duplicate key, take the spare key and the key tag to your dealer or a locksmith.

If you lose all ignition keys and the key tag, the ignition switch assembly will probably have to be removed by your dealer to determine the key number.

A metal key holder may cause damage to the area surrounding the ignition switch.

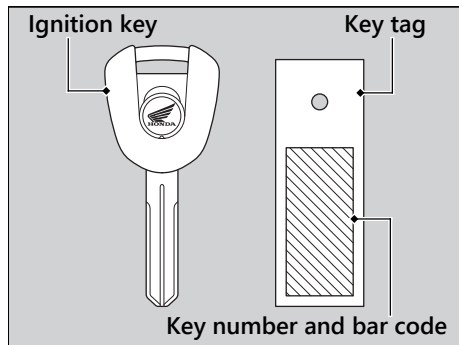

Instruments, Controls, & Other Features

Instruments, Controls, & Other Features

Ignition Switch

Leaving the ignition switch in the **I** (On) position with the engine stopped will drain the battery.

Do not turn the key while riding.

Engine Stop Switch

Do not use the engine stop switch except in an emergency. Doing so when riding will cause the engine to suddenly turn off, making riding unsafe.

If you stop the engine using the engine stop switch, turn the ignition switch to the **O** (Off) position. Failing to do so will drain the battery.

Odometer

The display locks at 999,999 when the read-out exceeds 999,999.

Tripmeter

The tripmeters return to 0.0 when each read-out exceeds 9,999.9.

Document Bag

The owner's manual, registration, and insurance information can be stored in the plastic document bag located underside of the rear seat.

Ignition Cut-off System

A banking (lean angle) sensor automatically stops the engine and fuel pump if the motorcycle falls over. To reset the sensor, you must turn the ignition switch to the **O** (Off) position and back to the **I** (On) position before the engine can be restarted.

Caring for Your Motorcycle

Caring for Your Motorcycle

Frequent cleaning and polishing is important to ensure the life of your Honda. A clean motorcycle makes it easier to spot potential problems.

In particular, seawater and salts used to prevent ice on roads promote the formation of corrosion. Always wash your motorcycle thoroughly after riding on coastal or treated roads.

Washing

Allow the engine, muffler, brakes, and other high-temperature parts to cool before washing.

1. Rinse your motorcycle thoroughly using a low pressure garden hose to remove loose dirt.
2. If necessary, use a sponge or a soft towel with mild cleaner to remove road grime.
 - ▶ Clean the headlight lens, panels, and other plastic components with extra care to avoid scratching them.
 Avoid directing water into the air cleaner, muffler, and electrical parts.

3. Thoroughly rinse your motorcycle with plenty of clean water and dry with a soft, clean cloth.
4. After the motorcycle dries, lubricate any moving parts.
 - ▶ Make sure that no lubricant spills onto the brakes or tyres. Brake discs, pads, drum or shoes contaminated with oil will suffer greatly reduced braking effectiveness and can lead to a crash.
5. Lubricate the drive chain immediately after washing and drying the motorcycle.
6. Apply a coat of wax to prevent corrosion.
 - ▶ Avoid products that contain harsh detergents or chemical solvents. These can damage the metal, paint, and plastic on your motorcycle.
 - ▶ Keep the wax clear of the tyres and brakes.
 - ▶ If your motorcycle has any mat painted parts, do not apply a coat of wax to the mat painted surface.

Caring for Your Motorcycle

Washing Precautions

Follow these guidelines when washing:

- Do not use high-pressure washers:
 - ▶ High-pressure water cleaners can damage moving parts and electrical parts, rendering them inoperable.
 - ▶ Water in the air intake can be drawn into the throttle body and/or enter the air cleaner.
- Do not direct water at the muffler:
 - ▶ Water in the muffler can prevent starting and causes rust in the muffler.
- Dry the brakes:
 - ▶ Water adversely affects braking effectiveness. After washing, apply the brakes intermittently at low speed to help dry them.
- Do not direct water under the seat:
 - ▶ Water in the under seat compartment can damage your documents and other belongings.

- Do not direct water at the air cleaner:
 - ▶ Water in the air cleaner can prevent the engine from starting.
- Do not direct water near the headlight:
 - ▶ The headlight's inside lens may fog temporarily after washing or while riding in the rain. This does not impact the headlight function.
However, if you see a large amount of water or ice accumulated inside the lens(es), have your vehicle inspected by your dealer.
- Do not use wax or polishing compounds on mat painted surface:
 - ▶ Use a soft cloth or sponge, plenty of water, and a mild detergent to clean mat painted surfaces. Dry with a soft clean cloth.

Information

Caring for Your Motorcycle

Aluminium Components

Aluminium will corrode from contact with dirt, mud, or road salt. Clean aluminium parts regularly and follow these guidelines to avoid scratches:

- Do not use stiff brushes, steel wool, or cleaners containing abrasives.
- Avoid riding over or scraping against curbs.

Panels

Follow these guidelines to prevent scratches and blemishes:

- Wash gently using a soft sponge and plenty of water.
- To remove stubborn stains, use diluted detergent and rinse thoroughly with plenty of water.
- Avoid getting petrol, brake fluid, or detergents on the instruments, panels, or headlight.

Exhaust Pipe and Muffler



When the exhaust pipe and muffler are painted, do not use a commercially available abrasive kitchen cleaning compound. Use a neutral detergent to clean the painted surface on the exhaust pipe and muffler. If you are not sure if your exhaust pipe and muffler are painted, contact your dealer.

Storing Your Motorcycle

Storing Your Motorcycle

If you store your motorcycle outdoors, you should consider using a full-body motorcycle cover.

If you won't be riding for an extended period, follow these guidelines:

- Wash your motorcycle and wax all painted surfaces (except mat painted surfaces). Coat chrome pieces with rust-inhibiting oil.
- Lubricate the drive chain.  P. 60
- Place your motorcycle on a maintenance stand and position a block so that both tyres are off the ground.
- After rain, remove the body cover and allow the motorcycle to dry.
- Remove the battery ( P. 67) to prevent discharge. Fully charge the battery and then place it in a shaded, well-ventilated area.
 - ▶ If you leave the battery in place, disconnect the negative \ominus terminal to prevent discharge.

After removing your motorcycle from storage, inspect all maintenance items required by the Maintenance Schedule.

Transporting Your Motorcycle

Transporting Your Motorcycle

If your motorcycle needs to be transported, it should be carried on a motorcycle trailer or a flatbed truck or trailer that has a loading ramp or lifting platform, and motorcycle tie-down straps. Never try to tow your motorcycle with a wheel or wheels on the ground.

Information

NOTICE

Towing your motorcycle can cause serious damage to the transmission.

You & the Environment

Owning and riding a motorcycle can be enjoyable, but you must do your part to protect the environment.

Choose Sensible Cleaners

Use a biodegradable detergent when you wash your motorcycle. Avoid aerosol spray cleaners that contain chlorofluorocarbons (CFCs) which damage the atmosphere's protective ozone layer.

Recycle Wastes

Put oil and other toxic wastes in approved containers and take them to a recycling centre. Call your local or state office of public works or environmental services to find a recycling centre in your area, and to get instructions on how to dispose of non-recyclable wastes. Do not place used engine oil in the trash, or pour it down a drain or on the ground. Used oil, petrol, coolant, and cleaning solvents contain poisons that can hurt refuse workers and contaminate drinking water, lakes, rivers, and oceans.

Serial Numbers

Serial Numbers

The frame and engine serial numbers uniquely identify your motorcycle and are required in order to register your motorcycle. They may also be required when ordering replacement parts.

You should record these numbers and keep them in a safe place.

Information

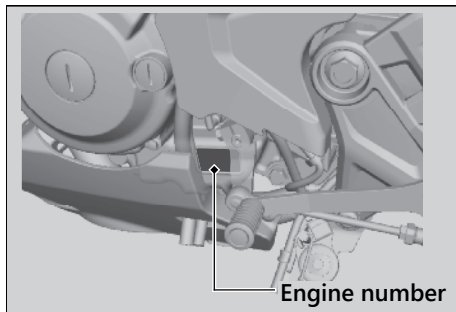
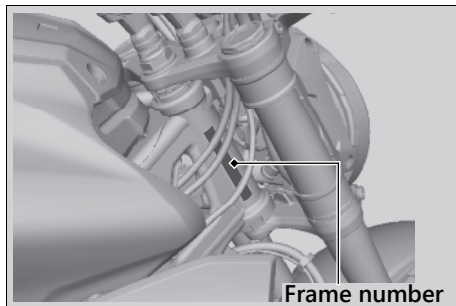

Fuels Containing Alcohol

Fuels Containing Alcohol

Some conventional fuels blended with alcohol are available in some locales to help reduce emissions to meet clean air standards. If you plan to use blended fuel, check that it is unleaded and meets the minimum octane rating requirement.

The following fuel blends can be used in your motorcycle:

- Ethanol (ethyl alcohol) up to 10% by volume.
 - ▶ Petrol containing ethanol may be marketed under the name Gasohol.

The use of petrol containing more than 10% ethanol may:

- Damage the painting of the fuel tank.
- Damage the rubber tubes of the fuel line.
- Cause corrosion of the fuel tank.
- Cause poor drivability.

NOTICE

Use of blended fuels containing higher than approved percentages can damage metal, rubber, plastic parts of your fuel system.

If you notice any undesirable operating symptoms or performance problems, try a different brand of petrol.

Catalytic Converter

Catalytic Converter

This motorcycle is equipped with a three-way catalytic converter. The catalytic converter contains precious metals that serve as catalysts in high temperature chemical reactions that convert hydrocarbons (HC), carbon monoxide (CO), and oxides of nitrogen (NOx) in the exhaust gasses into safe compounds.

Information

A defective catalytic converter contributes to air pollution and can impair your engine's performance. A replacement unit must be an original Honda part or equivalent.

Follow these guidelines to protect your motorcycle's catalytic converter.

- Always use unleaded petrol. Leaded petrol will damage the catalytic converter.
- Keep the engine in good running condition.
- Have your motorcycle serviced if your engine is misfiring, backfiring, stalling, or otherwise not running properly, stop riding and turn off the engine.

Specifications

■ Main Components

Overall length	2,020 mm (79.5 in)
Overall width	805 mm (31.7 in)
Overall height	1,050 mm (41.3 in)
Wheelbase	1,355 mm (53.3 in)
Minimum ground clearance	150 mm (5.9 in)
Caster angle	24° 44'
Trail	93 mm (3.7 in)
Curb weight	145 kg (320 lb)
Maximum weight capacity *1	180 kg (397 lb)
Maximum luggage weight	8 kg (18 lb)
Passenger capacity	Rider and 1 passenger
Minimum turning radius	2.30 m (7.5 ft)

*1 : Including rider, passenger, all luggage, and accessories

Displacement	CBF300NA
	286 cm ³ (17.4 cu-in)
	CBF250NA
	250 cm ³ (15.3 cu-in)
Bore x stroke	CBF300NA
	76.0 x 63.0 mm (2.99 x 2.48 in)
	CBF250NA
	76.0 x 55.0 mm (2.99 x 2.17 in)
Compression ratio	10.7 : 1
Fuel	Unleaded petrol Recommended: 91 RON or higher
Fuel containing alcohol	ETHANOL up to 10% by volume
Tank capacity	10.1 L (2.67 US gal, 2.22 Imp gal)
Battery	YTZ8V
	12 V-7 Ah (10 HR) / 7.4 Ah (20 HR)
Gear ratio	1st 3.416
	2nd 2.250
	3rd 1.650
	4th 1.350
	5th 1.166
	6th 1.038
Reduction ratio (primary / final)	2.807 / 2.571

Specifications

■ Service Data

Tyre size	Front	110/70R17M/C 54H
	Rear	150/60R17M/C 66H
Tyre type	Radial, tubeless	
Recommended Tyre	Front	DUNLOP GPR-300F M
	Rear	DUNLOP GPR-300 M
Tyre category of use *1	Normal	Permitted
	Special	Not Permitted
	Snow	Not Permitted
	Moped	Not Permitted
Tyre air pressure (Driver only)	Front	200 kPa (2.00 kgf/cm ² , 29 psi)
	Rear	225 kPa (2.25 kgf/cm ² , 33 psi)
Tyre air pressure (Driver and passenger)	Front	200 kPa (2.00 kgf/cm ² , 29 psi)
	Rear	225 kPa (2.25 kgf/cm ² , 33 psi)
Minimum tread depth	Front	1.5 mm (0.06 in)
	Rear	2.0 mm (0.08 in)
Spark plug	SIMR8A9 (NGK)	
Spark plug gap	0.80 - 0.90 mm (0.031 - 0.035 in)	
Idle speed	1,400 ± 100 rpm	
Recommended engine oil	Honda 4-stroke motorcycle oil, API Service Classification SG or higher, excluding oils marked as "Energy Conserving" or "Resource Conserving," SAE 10W-30, JASO T 903 standard MA	

Specifications

Engine oil capacity	After draining	1.4 L (1.5 US qt, 1.2 Imp qt)
	After draining & engine oil filter change	1.5 L (1.6 US qt, 1.3 Imp qt)
	After disassembly	1.8 L (1.9 US qt, 1.6 Imp qt)
Recommended brake fluid	Honda DOT 3 or DOT 4 Brake Fluid	
Cooling system capacity	0.79 L (0.83 US qt, 0.70 Imp qt)	
Recommended coolant	Pro Honda HP Coolant	
Recommended drive chain lubricant	Drive chain lubricant designed specifically for O-ring chains If not available, use SAE 80 or 90 gear oil.	
Drive chain slack	30 - 40 mm (1.2 - 1.6 in)	
Standard drive chain	DID 520VF or RK 520KLO2	
	No. of links	108
Standard sprocket size	Drive sprocket	14T
	Driven sprocket	36T

*1: EU regulation

Specifications

■ **Bulbs**

Headlight	LED
Brakelight/Taillight	LED
Front turn signal light	LED
Rear turn signal light	LED
License plate light	LED

■ **Fuses**

Main fuse	30 A
Other fuse	30 A, 20 A, 10 A, 7.5 A

■ **Torque Specifications**

Front seat mounting bolt	10 N·m (1.0 kgf·m, 7 lbf·ft)
Fuel tank cover bolt A	4.2 N·m (0.4 kgf·m, 3.1 lbf·ft)
Fuel tank cover bolt B	4.2 N·m (0.4 kgf·m, 3.1 lbf·ft)
Fuel tank cover bolt C	10 N·m (1.0 kgf·m, 7 lbf·ft)
Fuel tank cover bolt D	10 N·m (1.0 kgf·m, 7 lbf·ft)
Fuel tank mounting bolt	12 N·m (1.2 kgf·m, 9 lbf·ft)
Outer shroud bolt	4.2 N·m (0.4 kgf·m, 3.1 lbf·ft)
Inner shroud bolt A	4.2 N·m (0.4 kgf·m, 3.1 lbf·ft)
Inner shroud bolt B	10 N·m (1.0 kgf·m, 7 lbf·ft)
Engine oil drain bolt	24 N·m (2.4 kgf·m, 18 lbf·ft)
Engine oil filter cover bolt	12 N·m (1.2 kgf·m, 9 lbf·ft)
Rear axle nut	88 N·m (9.0 kgf·m, 65 lbf·ft)
Front axle nut	59 N·m (6.0 kgf·m, 44 lbf·ft)
Front axle pinch bolt	24 N·m (2.4 kgf·m, 18 lbf·ft)

Index

A

ABS (Anti-lock Brake System)	12, 103
ABS (Anti-lock Brake System) indicator	36, 103
Accessories	14
Air Cleaner	65
Average Speed Meter	19, 26

B

Battery	56, 67
Brakelight Switch	86
Brakelight/Taillight	113

Brakes

Fluid	59, 84, 130
Pad Wear	85

Braking	11
---------------	----

Bulb

Brakelight/Taillight	113
Front Turn Signal Light	114
Headlight	113
License Plate Light	114
Rear Turn Signal Light	114

C

Caring for Your Motorcycle	120
Catalytic Converter	128
Clip	69
Clock	19, 28
Clutch	
Freeplay	92, 93
Clutch System	92
Coolant	61, 82
Coolant Temperature Gauge	19, 101
Crankcase Breather	62, 96
Crash	5

D

Digital Clock Adjustment	28
Document Bag	48, 119
Drive Chain	60, 88
Drive Chain Slider	91

E

Electrical Trouble	112
--------------------------	-----

Engine

Number	126
Oil	58, 78
Oil Filter	80
Overheats	101
Starting	43
Stop Switch	40, 119
Stopping	119
Will Not Start	100

Environment 125**Equipment**

Document Bag	48
Helmet Holder	47
Owner's Manual	119
Tool Kit	48

F**Flooded Engine** 43**Frame Number** 126**Front Seat** 70**Front Turn Signal Light** 114**Fuel**

Average Fuel Mileage Meter	19, 25
Consumption Meter	19, 26

Containing Alcohol	127, 129
--------------------------	----------

Current Fuel Mileage Meter	19, 25
----------------------------------	--------

Gauge	19, 104
-------------	---------

Recommended	46, 129
-------------------	---------

Remaining	19
-----------------	----

Tank Capacity	46, 129
---------------------	---------

Fuses 58, 115**G****Gasohol** 127**H****Headlight** 113**Headlight Aim** 97**Headlight Dimmer Switch** 40**Helmet Holder** 47**High Beam Indicator** 37**Horn Button** 40**I****Ignition Cut-off System**

Banking Sensor	119
----------------------	-----

Side Stand	87
------------------	----

Ignition Key 118

Ignition Switch.....	41, 43, 119	N	
Image Labels.....	6	Neutral Indicator	37
Indicators.....	36	O	
Instruments.....	18	Odometer.....	19, 21, 119
Instruments, Controls, & Other		Oil	
Features	119	Engine	58, 78
K		Overheating.....	101
Keys.....	118	P	
L		Parking	13
Labels.....	6	Parts Location.....	16
License Plate Light.....	114	Passing Light Control Switch	40
Load Limits.....	15	Petrol	46
Loading Guidelines.....	15	PGM-FI (Programmed Fuel Injection)	
M		Malfunction Indicator Lamp (MIL)....	36, 102
Maintenance		Protective Apparel.....	10
Fundamentals	54	R	
Importance	50	Rear Seat.....	75
Safety	50	Rear Suspension.....	98
Schedule.....	51	Rear Turn Signal Light.....	114
Maximum Weight Limit	15		
Modifications.....	14		

Recommended

Coolant.....	61, 130
Engine Oil.....	58, 130
Fuel.....	46

Refuelling..... 46**Removal**

Battery.....	67
Clip.....	69
Front Seat.....	70
Fuel Tank Cover Assembly.....	71
Fuel Tank Maintenance Position.....	73
Rear Seat.....	75
Shroud.....	76

Repair Kit..... 105**REV Indicator..... 31, 37****Riding Precautions..... 11****S**

Safety Guidelines.....	3
Safety Precautions.....	10
SEL button.....	18
Serial Numbers.....	126
SET button.....	18
Shifting Gears.....	45

Side Stand..... 87**Side Stand Ignition Cut-off System..... 87****SIDE STAND indicator..... 37****Specifications..... 129****Speedometer..... 19****Start Button..... 40****Starting the Engine..... 43****Steering Lock..... 42****Stopping Engine..... 119****Stopwatch..... 19, 21, 23****Storage**

Equipment.....	47
Owner's Manual.....	119
Tool Kit.....	48

Storing..... 123**Switches..... 40****T**

Tachometer.....	18
Tachometer Display.....	35
Throttle.....	95
Tool Kit.....	48, 66
Transporting Your Motorcycle.....	124
Tripmeter.....	19, 21, 119

Troubleshooting	99
Turn Signal Indicator	37
Turn Signal Switch	40
Tyres	
Air Pressure	62
Puncture.....	105
Replacing	62, 105
W	
Warning Indicators On or Flashing	102
Washing Your Motorcycle	120
Weight Limit	15, 129
Wheels	
Front Removal	106
Rear Removal.....	109